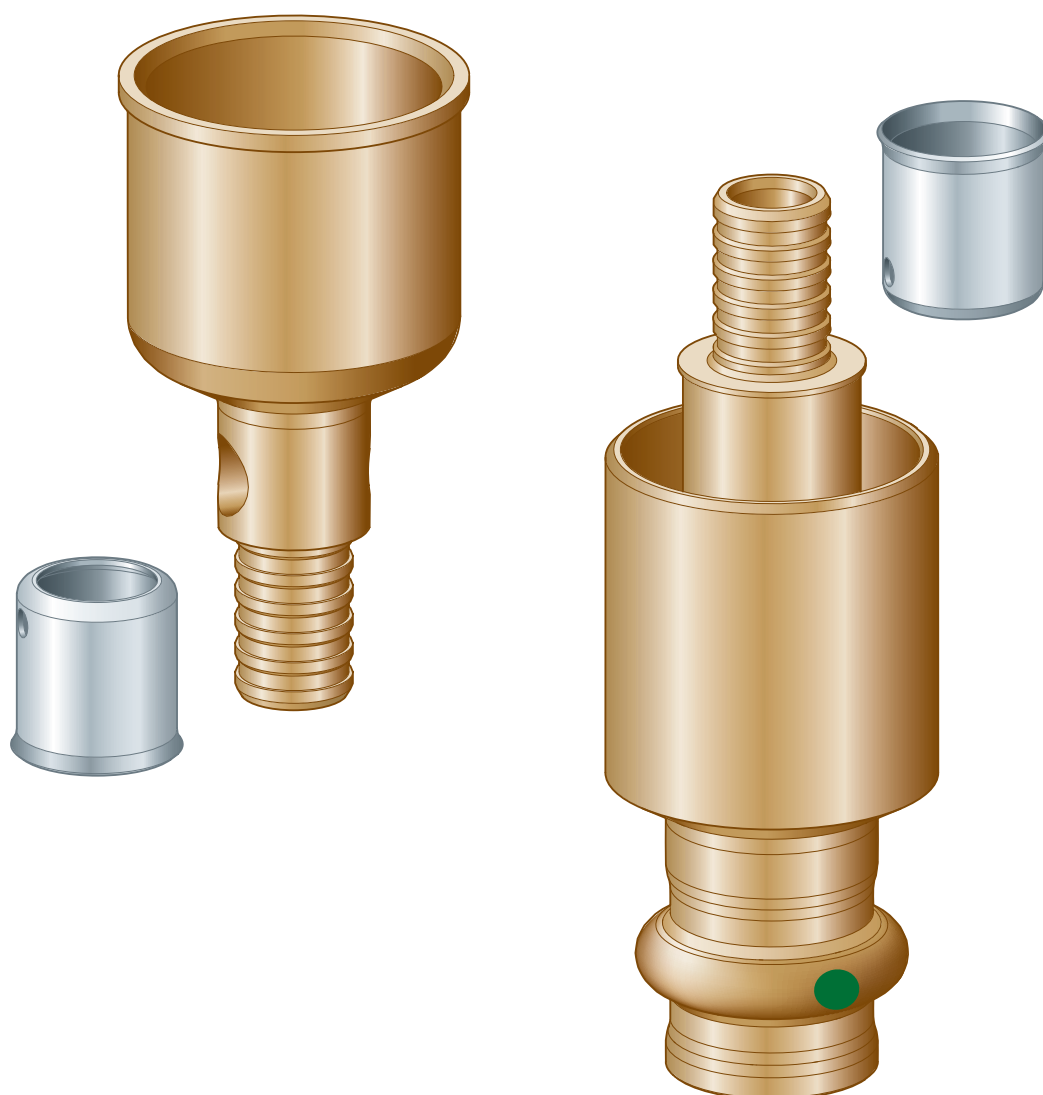


# Instructions for Use

## Smartloop connection set



**Model**  
2276.1

**Year built (from)**  
07/2008

**viega**

# Table of contents

<b>1</b>	<b>About these instructions for use</b>	<b>3</b>
	1.1 Target groups	3
	1.2 Labelling of notes	3
	1.3 About this translated version	4
<b>2</b>	<b>Product information</b>	<b>5</b>
	2.1 Standards and regulations	5
	2.2 Intended use	7
	2.2.1 Areas of application	8
	2.2.2 Media	8
	2.3 Product description	8
	2.3.1 Overview	8
	2.3.2 press connector with SC-Contur	12
	2.3.3 Sealing elements	13
	2.3.4 Markings on components	13
	2.3.5 Compatible components	14
	2.3.6 Technical data	14
	2.4 Information for use	15
	2.4.1 Permitted mixed installations	15
	2.4.2 Corrosion	15
<b>3</b>	<b>Handling</b>	<b>16</b>
	3.1 Assembly information	16
	3.1.1 Permitted exchange of sealing elements	16
	3.1.2 Mounting instructions	16
	3.1.3 Required tools	17
	3.2 Assembly	18
	3.2.1 Replacing the sealing element	18
	3.2.2 Installing Smartloop	19
	3.2.3 Leakage test	23
	3.3 Maintenance	23
	3.4 Repairing the riser pipe	24
	3.5 Disposal	26

# 1 About these instructions for use

Trade mark rights exist for this document; for further information, go to [viega.com/legal](http://viega.com/legal).

## 1.1 Target groups

The information in this manual is directed at heating and sanitary professionals and trained personnel.

Individuals without the abovementioned training or qualification are not permitted to mount, install and, if required, maintain this product. This restriction does not extend to possible operating instructions.

The installation of Viega products must take place in accordance with the general rules of engineering and the Viega instructions for use.

## 1.2 Labelling of notes

Warning and advisory texts are set aside from the remainder of the text and are labelled with the relevant pictographs.



### **DANGER!**

This symbol warns of possible life-threatening injury.



### **WARNING!**

This symbol warns of possible serious injury.



### **CAUTION!**

This symbol warns of possible injury.



### **NOTICE!**

This symbol warns of possible damage to property.



This symbol gives additional information and hints.

### 1.3 About this translated version

This instruction for use contains important information about the choice of product or system, assembly and commissioning as well as intended use and, if required, maintenance measures. The information about the products, their properties and application technology are based on the current standards in Europe (e.g. EN) and/or in Germany (e.g. DIN/DVGW).

Some passages in the text may refer to technical codes in Europe/Germany. These should serve as recommendations in the absence of corresponding national regulations. The relevant national laws, standards, regulations, directives and other technical provisions take priority over the German/European directives specified in this manual: The information herein is not binding for other countries and regions; as said above, they should be understood as a recommendation.

## 2 Product information

### 2.1 Standards and regulations

The following standards and regulations apply to Germany / Europe and are provided as a support feature.

#### Regulations from section: Fields of application

Scope / Notice	Regulations applicable in Germany
Planning, execution, operation and maintenance of drinking water installations	DIN EN 806, part 1-5
Planning, execution, operation and maintenance of drinking water installations	DIN EN 1717
Planning, execution, operation and maintenance of drinking water installations	DIN 1988
Planning, execution, operation and maintenance of drinking water installations	VDI/DVGW 6023
Planning, execution, operation and maintenance of drinking water installations	Trinkwasserverordnung (TrinkwV)
Planning, execution, operation and maintenance of drinking water installations	DVGW-Arbeitsblatt W 553

#### Regulations from section: Media

Scope / Notice	Regulations applicable in Germany
Suitability for potable water	DIN 1988-200
Suitability for potable water	EN 806-2

**Regulations from section: Product description**

Scope / Notice	Regulations applicable in Germany
Suitability for drinking water	DIN 50930-6
Suitability for drinking water	Trinkwasserverordnung (TrinkwV)
Compliance of the plastic components	KTW-Empfehlung
Compliance of the plastic components	DVGW-Arbeitsblatt W 270

**Regulations from section: Compatible components**

Scope / Notice	Regulations applicable in Germany
Certification and approval of press connectors	DVGW-Arbeitsblatt W 534
Certification and approval of press connectors for use with copper pipes	DVGW-Arbeitsblatt GW 392
Certification and approval of press connectors for use with copper pipes	DIN EN 1057
Certification and approval of press connectors for use with stainless steel pipes (material 1.4401 / 1.4521)	DVGW-Arbeitsblatt GW 541
Certification and approval of press connectors for use with stainless steel pipes (material 1.4401 / 1.4521)	DIN EN 10312
Certification and approval of press connectors for use with stainless steel pipes (material 1.4401 / 1.4521)	DIN EN 10088

### Regulations from section: Corrosion

Scope / Notice	Regulations applicable in Germany
Regulations for external corrosion protection	DIN EN 806-2
Regulations for external corrosion protection	DKI-Informationsdruck i. 160
Regulations for external corrosion protection	DIN 1988-200
Regulation on material selection	DIN 50930-6
Regulations for the selection of material	DIN EN 12502-1

### Regulations from section: Leakage test

Scope / Notice	Regulations applicable in Germany
Regulations for leakage tests	DIN EN 806-4
Regulations for leakage tests	ZVSHK Merkblatt "Dichtheitsprüfungen von Trinkwasserinstallationen mit Druckluft, Inertgas oder Wasser"

### Regulations from section: Maintenance

Scope / Notice	Regulations applicable in Germany
Operation and maintenance of drinking water installations	DIN EN 806-5

## 2.2 Intended use



The press connector system is suitable for the construction of drinking water installations in accordance with applicable guidelines, taking into account the selection of materials in accordance with applicable guidelines and in accordance with the assessment basis for metallic materials in contact with drinking water of the Federal Environment Agency (UBA), see [☞ 'Regulations from section: Fields of application' on page 5](#). For use in other areas of application and in case of doubt over the correct material selection, contact Viega.

## 2.2.1 Areas of application

The Smartloop Inliner technology is employed as an internal circulation pipe in potable water installations. The system is particularly suitable for hot water riser pipes from d 28.

The general rules of engineering must be observed for planning, execution, operation and maintenance potable water installations, see [↗ 'Regulations from section: Fields of application' on page 5](#).

Viega recommends using the planning software Viega Viptool when dimensioning a potable water installation with Smartloop Inliner technology.

## 2.2.2 Media

The system is suitable for the following media:

- Potable water
  - see [↗ 'Regulations from section: Media' on page 5](#)
  - max. chloride concentration 250 mg / l (in acc. with DWO)

## 2.3 Product description

The Smartloop inliner technology can be used for potable water installations in accordance with applicable guidelines, see [↗ 'Regulations from section: Product description' on page 6](#).

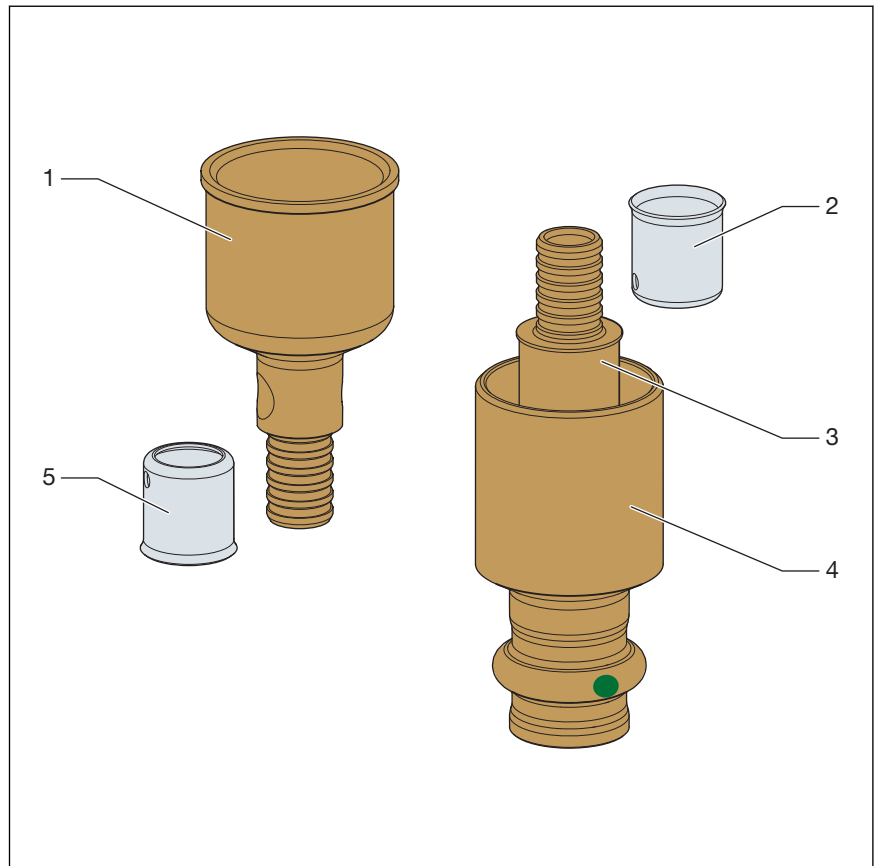
The plastic components correspond to the applicable regulations, see [↗ 'Regulations from section: Product description' on page 6](#).

### 2.3.1 Overview

The Smartloop system consists of the following components:

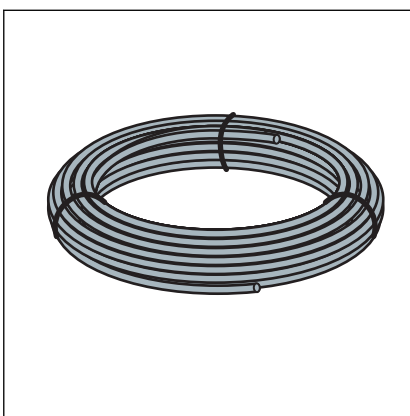
- Smartloop connection set (model 2276.1)
- Smartloop pipe (model 2007.3)
- Smartloop tension coupling (model 2276.9)
- Smartloop repair coupling (model 2276.8)



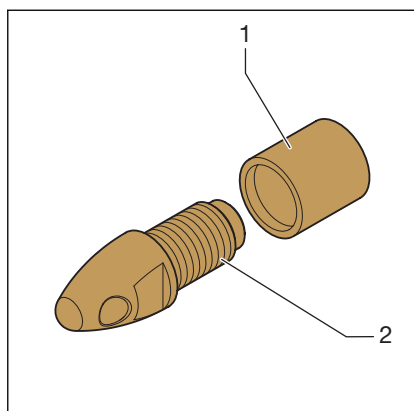


**Fig. 1: Connection set, model 2276.1**

- 1 - End closing piece
- 2 - Press sleeve
- 3 - Adapter
- 4 - Connecting piece
- 5 - Press sleeve

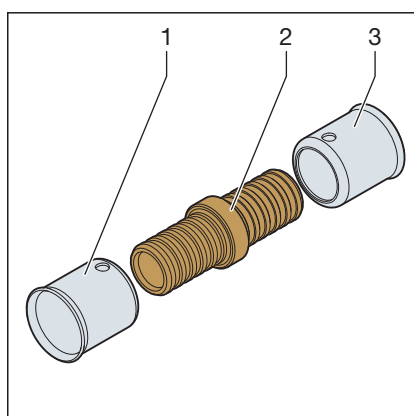


**Fig. 2: Pipe, model 2007.3**



- 1 - Support sleeve
- 2 - Tension head

**Fig. 3: Tension coupling, model 2276.9**



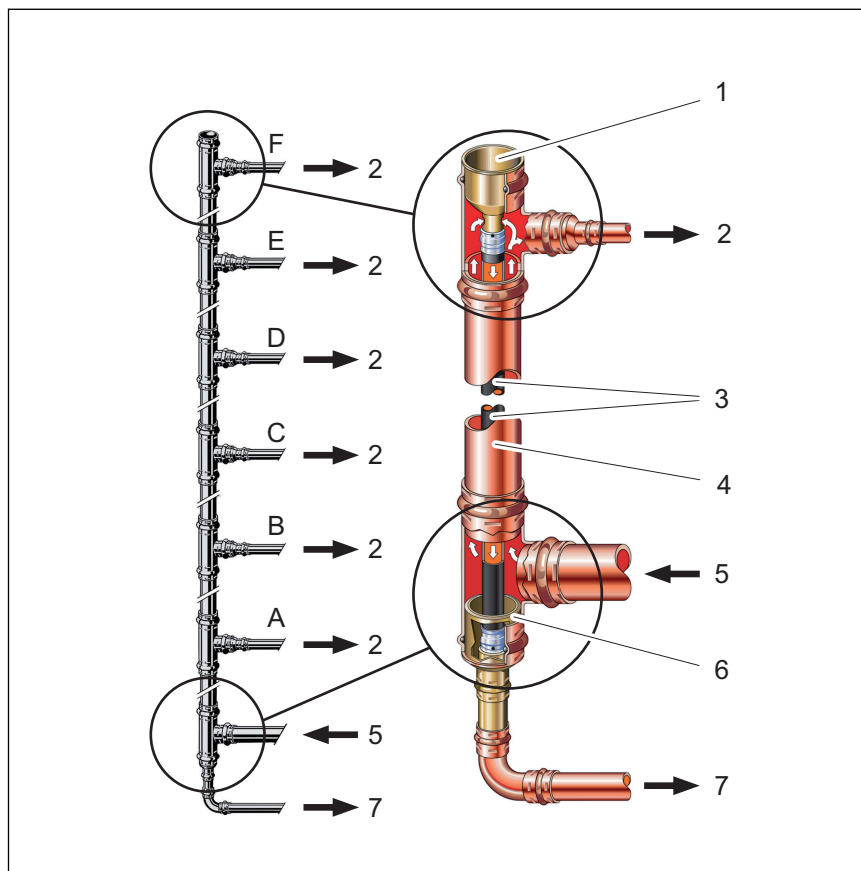
- 1 - Press sleeve
- 2 - Repair nipple
- 3 - Press sleeve

**Fig. 4: Repair coupling, model 2276.8**

The system components are available in the following dimensions:

- End closing piece/connecting piece d = 28, 35, 28 / 35
- Smartloop pipe d = 12

Operating mode



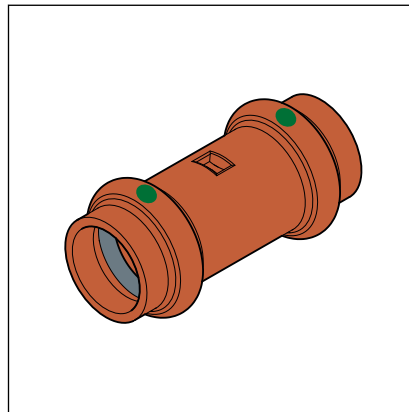
**Fig. 5: Functional principle Smartloop inliner technology**

- 1 - End closing piece
- 2 - Floor connection pipeline hot water
- 3 - Internally positioned circulation pipe
- 4 - Hot water riser pipe
- 5 - Hot water supply pipe
- 6 - Connecting piece
- 7 - Circulation collector line
- A-F - Ground to 5th floor

The circulation of hot water in the section is achieved as follows: Water is directed back into the hot water heating system and replaced by hot water via the opening in the end closing piece (1) of the last T-piece (2). This ensures that sufficient hot water is available at perfectly hygienic temperatures at every floor connection line.

The temperature in the riser pipe area does not continually drop in the direction of flow with Smartloop inliner circulation. The lowest temperature in the riser pipe is therefore at the end closing piece, in the area of the diversion in the internal circulation. With large-scale systems with several lines, this leads to an increase in the temperature in the circulation collector pipe. As a result, the temperature of the return flow water is higher than with conventional circulation systems, which, in turn, has advantages in terms of energy.

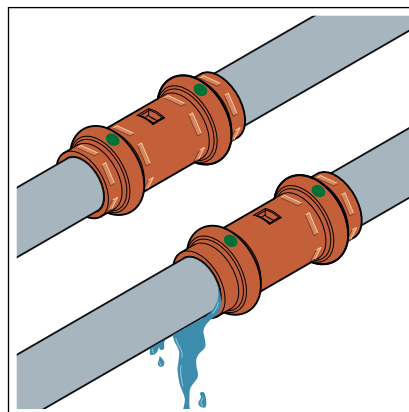
### 2.3.2 press connector with SC-Contur



**Fig. 6: Press connection using a press connector as an example**

The press connection has a circumferential bead in which the sealing element lies. The connector is deformed upstream and downstream of the bead and permanently connected to the pipe during pressing. The sealing element is not deformed during pressing.

### SC-Contur



**Fig. 7: SC-Contur**

Viega press connectors are equipped with the SC-Contur. The SC-Contur is a safety technology that is certified by the DVGW and ensures that the connection is guaranteed to be leaky in an unpressed state. In this way, inadvertently unpressed connections are noticed immediately during a leakage test.

Viega guarantees that unpressed connections are visible during a leakage test:

- with the wet leakage test in the pressure range from 0.1–0.65 MPa (1.0–6.5 bar)
- With dry leakage test in the pressure range from 22 hPa–0.3 MPa (22 mbar–3.0 bar)

### 2.3.3 Sealing elements

#### Area of use of the EPDM sealing element



#### NOTICE!

Only EPDM sealing elements are approved in potable water installations. The use of other sealing elements is not permitted.

The model is factory-fitted with EPDM sealing elements.

Operating temperature	70 °C (T <sub>max</sub> = 95 °C)
Operating pressure	1.0 MPa (10 bar) P <sub>max</sub> = 1.6 MPa (16 bar)
Comments	see notes ↗ Chapter 2.2.2 'Media' on page 8

### 2.3.4 Markings on components

#### Pipe marking

The pipe markings contain important information regarding the material configuration and manufacture of the pipes. Their meaning is as follows:

- Manufacturer
- System name
- Pipe material
- Certification
- Dimension
- Length specification
- Date of manufacture
- Batch number
- Manufacturing standard

#### Markings on press connectors

The press connectors are marked with a coloured dot. The dot identifies the SC-Contur where the test medium would escape in the case of an inadvertently unpressed connection.

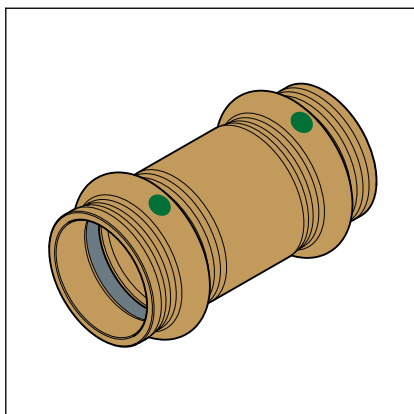


Fig. 8: Marking on the press connector

The green dot indicates that the system is suitable for potable water and is equipped with the SC-Contur.

### 2.3.5 Compatible components

The model is equipped with press connections and compatible with the Profipress, Sanpress and Sanpress Inox system.

#### Pipes

The press connections are tested and approved according to the applicable regulations with the following pipe types:

- Copper pipes
  - see ↗ 'Regulations from section: Compatible components' on page 6
- Stainless steel pipes (material 1.4401 / 1.4521)
  - see ↗ 'Regulations from section: Compatible components' on page 6

### 2.3.6 Technical data

Observe the following operating conditions for the installation of the system:

Operating temperature	70 °C
	T <sub>max</sub> 95 °C
Operating pressure	1.0 MPa (10 bar)
	P <sub>max</sub> 1.6 MPa (16 bar)
Comments	see notes ↗ Chapter 2.2.2 'Media' on page 8

## 2.4 Information for use

### 2.4.1 Permitted mixed installations

Generally, components from different piping systems should not be used in the same installation. The different materials may have a detrimental effect on each other e. g. cause corrosion.

Generally, components from the Viega systems Profipress, Sanpress and Sanpress Inox can be used in the Smartloop system.



The flow rules must be observed in all mixed installations with different metals.

Should you have any questions on this subject, please contact the Viega Service Center.

### 2.4.2 Corrosion

Overground pipelines and fittings in rooms do not normally require external corrosion protection.

There are exceptions in the following cases:

- Contact with aggressive building materials such as nitrite or materials containing ammonium
- in aggressive surroundings

If external corrosion protection is required, observe the pertinent regulation, see ↗ *'Regulations from section: Corrosion'* on page 7.



The press connector system is suitable for creating potable water installations in accordance with applicable directives, taking into consideration the material selection in accordance with applicable directives, see ↗ *'Regulations from section: Corrosion'* on page 7. For use in other areas of application and in case of doubt over the correct material selection, contact the Viega Service Center.

The chloride concentration in the medium must not exceed a maximum value of 250 mg/l.

This chloride is not a disinfectant, but in fact pertains to the content in sea and table salt (sodium chloride).

## 3 Handling

### 3.1 Assembly information

#### 3.1.1 Permitted exchange of sealing elements



##### Important instruction

With their material-specific qualities, sealing elements in press connectors are adapted for use with the corresponding media and/or the areas of use of the piping systems and are generally only certified for them.

The exchange of a sealing element is generally permitted. The sealing element must be exchanged for a designated spare part for the intended application ↪ *Chapter 2.3.3 'Sealing elements' on page 13*. The use of other sealing elements is not permitted.

#### 3.1.2 Mounting instructions

##### Checking system components



Do not remove the parts from the packaging until immediately before use.

System components may, in some cases, become damaged through transportation and storage.

- Check all parts.
- Replace damaged components.
- Do not repair damaged components.
- Contaminated components may not be installed.

##### Laying and fixing pipes

For information, refer to the instructions for use of the Profipress, Sanpress and Sanpress Inox systems.

##### Length expansion

For information, refer to the instructions for use of the Profipress, Sanpress and Sanpress Inox systems.



### 3.1.3 Required tools

#### Press connection

The following tools are required for production of a press connection:

- Pipe cutter or a fine-toothed hacksaw
- Deburrer and coloured pen for marking
- Press machine with constant pressing force
- Press jaw or press ring with corresponding hinged adapter jaw, suitable for the pipe diameter and with suitable profile

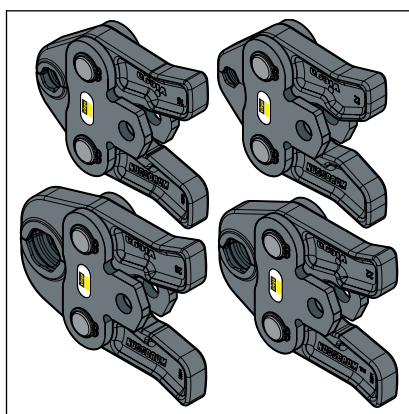


Fig. 9: Press jaws



#### **Viega recommends the use of Viega system tools when installing the press fittings.**

The Viega system press tools have been developed and tailored specifically for the installation of Viega press connector systems.

#### Smartloop pipe

The following tools are required for mounting the Smartloop pipe:

- Pipe shear, e.g. model 2040
- Mounting pliers, e.g. model 1077.2
- Hand press tool, e.g. model 2782
- Or press jaw, model 2799.7

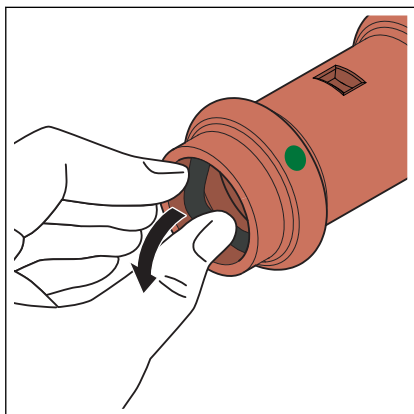
## 3.2 Assembly

### 3.2.1 Replacing the sealing element

#### Removing the sealing element

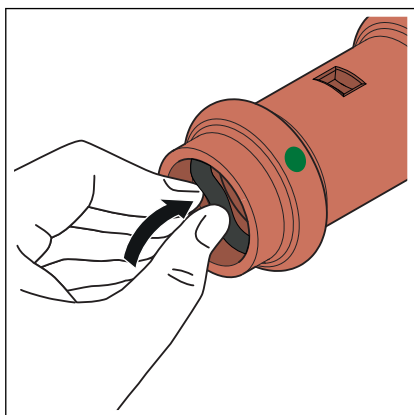


Do not use pointed or sharp-edged objects to remove the sealing element. They may damage the sealing element or the bead.



- Remove the sealing element from the bead.

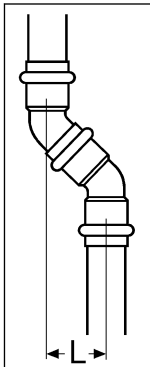
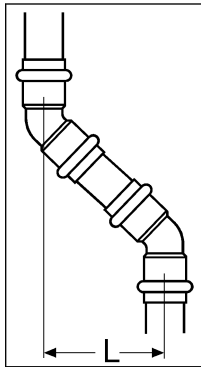
#### Inserting the sealing element



- Insert a new, undamaged sealing element into the bead.
- Ensure that the complete sealing element is in the bead.

### 3.2.2 Installing Smartloop

#### Maximum offset of the circulation pipe

Offset	Slight	45°
		
Diversion L [mm]	≥40–45	≥45–500
Components required	1 elbow 45° 1 elbow 45° with plug-in end	2 elbows 45°

Any installation variations differing from those shown should be agreed with the Viega Service Center.

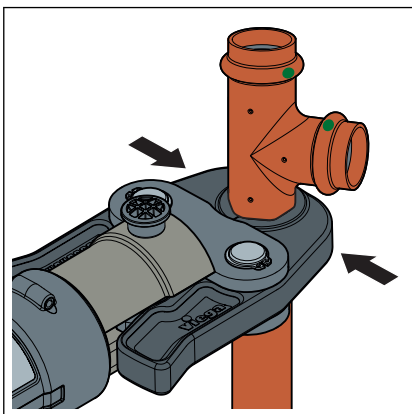
#### Procedure

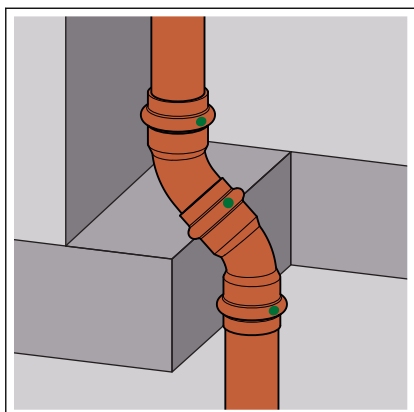


Pressing with a handtool is shown in the following assembly steps. Alternatively, a suitable Viega press machine with the corresponding press jaws can be used [Chapter 3.1.3 'Required tools' on page 17.](#)

#### Requirements:

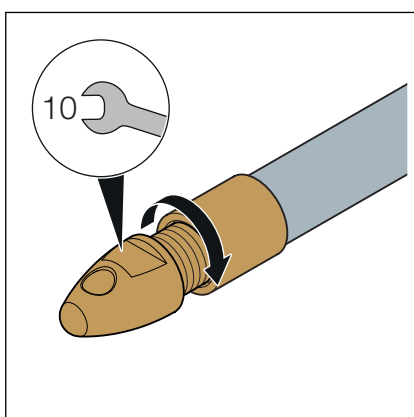
- The riser pipe is created.
- The riser pipe consists of Profipress, Sanpress or Sanpress Inox components.
- The riser pipe dimension is at least d 28 and maximum d 35.
- Press a T-piece onto the top end and onto the bottom end of the riser pipe.
- Create storey connection pipes in d 22, reduce if necessary.





- Only carry out one offset per line ↪ 'Maximum offset of the circulation pipe' on page 19.

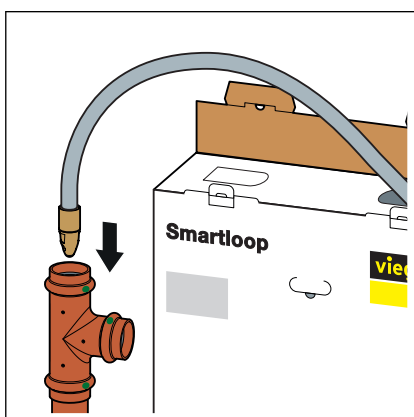
**INFO!** Other redirections only after consultation with the Viega Service Center.



- Install the pipe in the riser pipe.

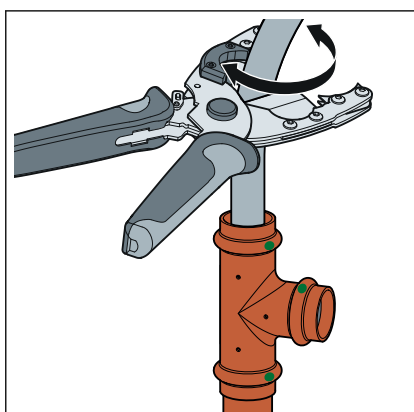
Viega recommends mounting the tension coupling model 2276.9 onto the pipe end.

Alternative: Chamfer the pipe with a file.

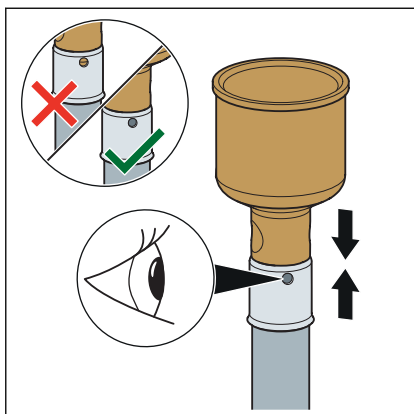


- Push the pipe into the hot water pipe from above.

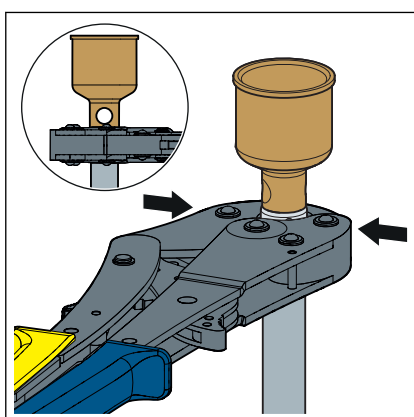
The pipe must protrude from the lower end of the riser pipe by approx. 30 cm.



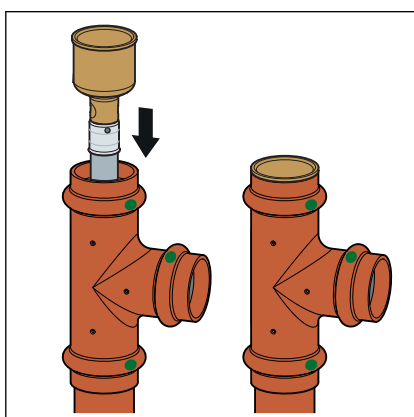
- Cut pipe to length.



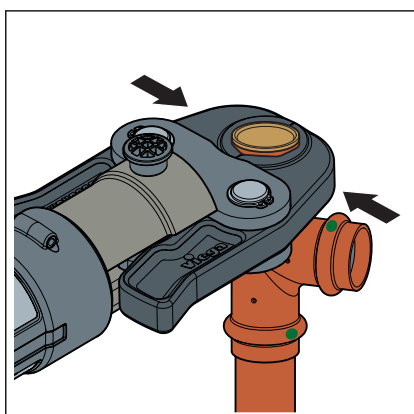
- Push a press sleeve onto the top pipe end.
- Push the end closing piece into the Smartloop pipe.
- Check the insertion depth in the inspection window.



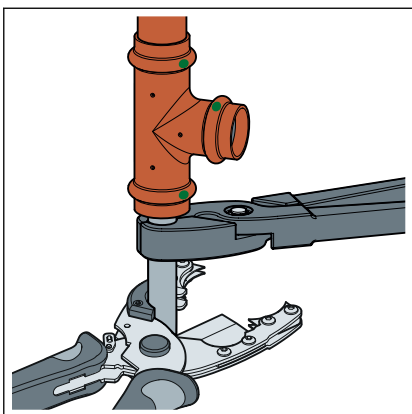
- Apply the press tool at a right-angle.
- When pressing, press the hand press tool until the pliers can be re-opened.



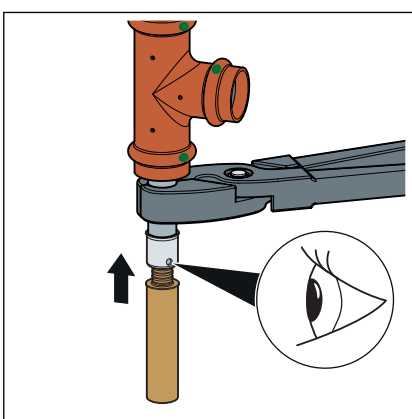
- Insert the end closing piece into the upper T-piece of the hot water pipe.  
If necessary, use a reducer.



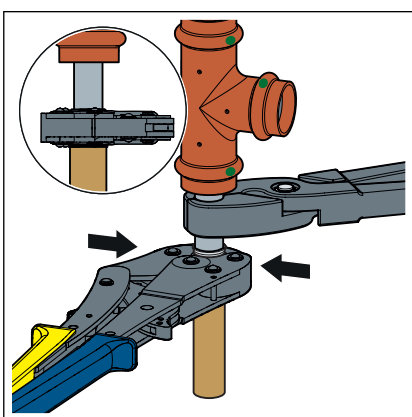
- Press the connection.



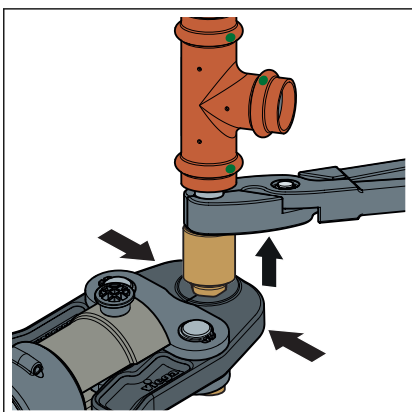
- Tighten the pipe on the lower end using the mounting pliers.
- Continue to hold the pipe tightly and shorten properly 40 mm below the T-piece.



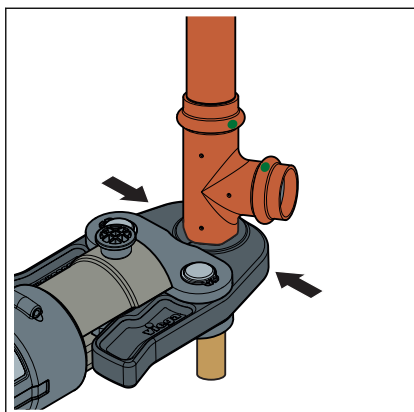
- Push a press sleeve onto the lower pipe end.
- Push the adapter into the pipe.
- Check the insertion depth in the inspection window.



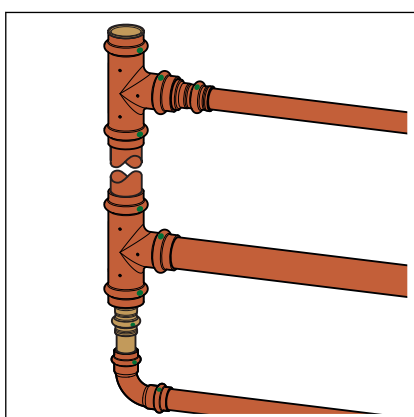
- Apply the press tool at a right-angle.
- When pressing, press the hand press tool until the pliers can be re-opened.



- Push the connecting piece into the adapter as far as it will go and press.
- Remove the mounting pliers.



- Insert the connecting piece into the lower T-piece of the hot water pipe as far as it will go and press.



- Connect the hot water pipe and the circulation pipe to the corresponding cellar supply and collector lines.
- Perform a leakage test.

### 3.2.3 Leakage test

The installer must perform a leakage test before commissioning.

Carry out this test on a system that is finished but not covered yet.

Comply with the general rules of engineering and the applicable directives, see [☞ 'Regulations from section: Leakage test' on page 7.](#)

Document the result.

## 3.3 Maintenance



### NOTICE!

Inform your customer or the operator of the potable water installation that the system has to be maintained on a regular basis.

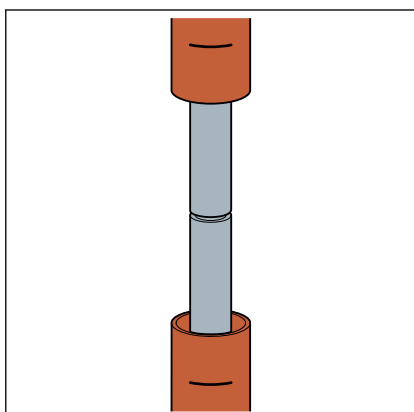
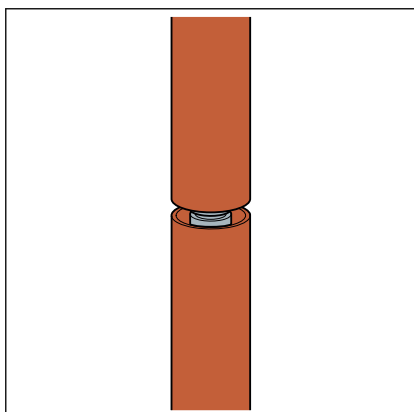
Observe the applicable regulations for the operation and maintenance of potable water installations, see [☞ 'Regulations from section: Maintenance' on page 7.](#)

### 3.4 Repairing the riser pipe

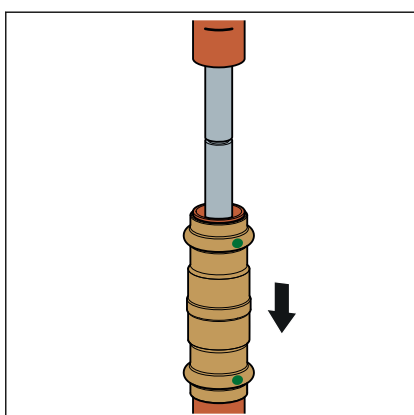
The repair coupling (model 2276.8) can be used in the case of a damaged riser pipe or an extension of the installation.

Material required:

- Repair coupling with two press sleeves, model 2276.8
- Sanpress slip coupling, model 2215.5
- Sanpress repair sliding sleeve, model 2215.4
- Cut all the way through the riser pipe and Smartloop pipe.

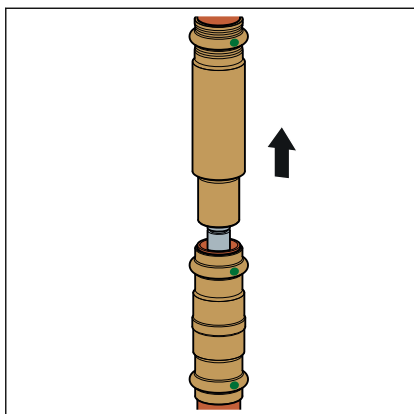


- Measure and mark the length of the repair sliding coupling.
- Remove the section of piping from the riser pipe.
- Mark the minimum insertion depth on the upper and lower pipe.

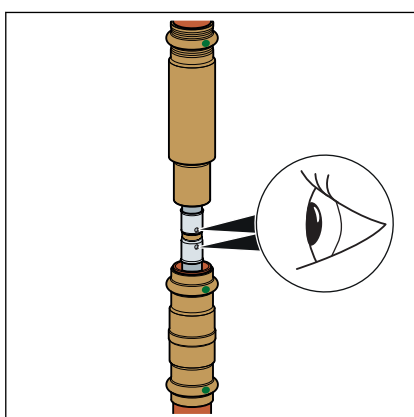


- Push the sliding coupling (model 2215.5) onto the lower pipeline completely.

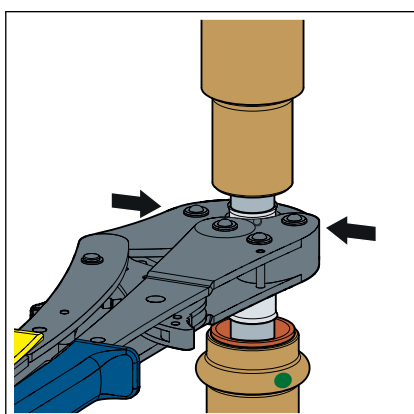




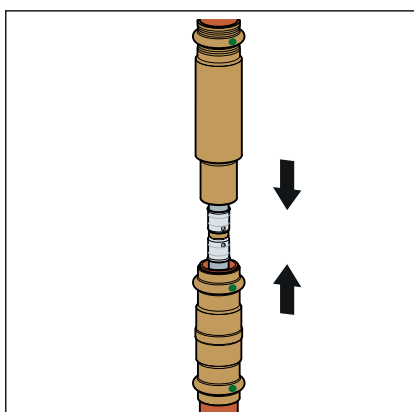
- Push the sliding coupling (model 2215.4) as far as it will go onto the upper pipeline.



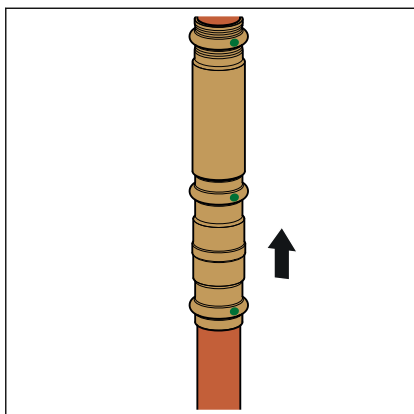
- Mount repair coupling on the Smartloop pipe.
- Check the insertion depth in the inspection window.



- Press the press sleeves. When doing so, apply the press tool at a right-angle.
- When pressing, press the manual pliers in one action until the pliers can be re-opened.

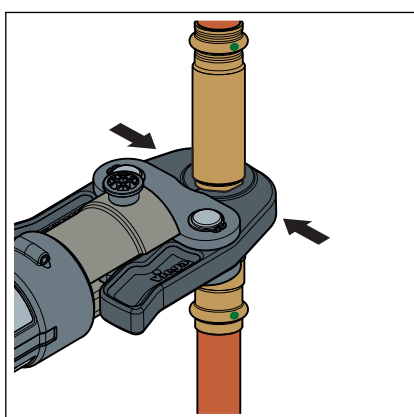


- Push the sliding couplings together.



- Position the sliding couplings in such a way that the minimum insertion depth is achieved:

The markings of the insertion depth are not visible.



- Press the pressing points of both sliding couplings.

### 3.5 Disposal

Separate the product and packaging materials (e. g. paper, metal, plastic or non-ferrous metals) and dispose of in accordance with valid national legal requirements.



**Viega GmbH & Co. KG**  
service-technik@viega.de  
viega.com

INT • 2022-05 • VPN220169

