

Instructions for Use

Advantix-shower channel with Advantix-grate Visign ER10

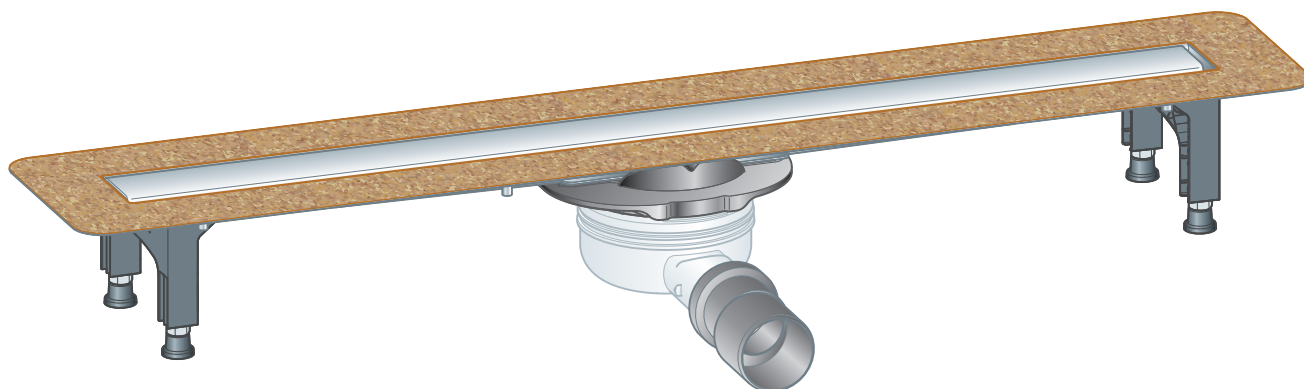

For bonded sealing (tiled shower) or sealing lane

Model
4983.10

Year built (from)
11/2019

viega

Table of contents

1	About these instructions for use	4
	1.1 Target groups	4
	1.2 Labelling of notes	4
	1.3 About this translated version	5
2	Product information	6
	2.1 Standards and regulations	6
	2.2 Certification	7
	2.3 Intended use	7
	2.3.1 Areas of application	7
	2.3.2 Media	8
	2.3.3 Drainage capacity	8
	2.4 Product description	9
	2.4.1 Overview	9
	2.4.2 Technical data	10
	2.5 Information for use	10
	2.5.1 Sealing	10
	2.5.2 Fire protection	13
	2.6 Required accessories	13
3	Assembly	14
	3.1 Assembly information	14
	3.1.1 Important note	14
	3.1.2 Installation dimensions	15
	3.1.3 Tools and materials	15
	3.2 Determine height	16
	3.3 Mounting base unit	16
	3.4 Aligning shower channel	19
	3.5 Connecting shower channel	19
	3.6 Preparing for further work	20
	3.7 Sealing the shower channel	22
	3.8 Installation in tiled floors	27
	3.9 Installation in self-levelling coating	30
4	Care	35
	4.1 Care tips	35

	4.2 Cleaning	35
5	Disposal	39

1 About these instructions for use

Trade mark rights exist for this document; for further information, go to viega.com/legal.

1.1 Target groups

The information in this instruction manual is directed at the following groups of people:

- Heating and plumbing experts and trained personnel

Individuals without the abovementioned training or qualification are not permitted to mount, install and, if required, maintain this product. This restriction does not extend to possible operating instructions.

The installation of Viega products must take place in accordance with the general rules of engineering and the Viega instructions for use.

1.2 Labelling of notes

Warning and advisory texts are set aside from the remainder of the text and are labelled with the relevant pictographs.



DANGER!

This symbol warns of possible life-threatening injury.



WARNING!

This symbol warns of possible serious injury.



CAUTION!

This symbol warns of possible injury.



NOTICE!

This symbol warns of possible damage to property.



This symbol gives additional information and hints.

1.3 About this translated version

This instruction for use contains important information about the choice of product or system, assembly and commissioning as well as intended use and, if required, maintenance measures. The information about the products, their properties and application technology are based on the current standards in Europe (e.g. EN) and/or in Germany (e.g. DIN/DVGW).

Some passages in the text may refer to technical codes in Europe/Germany. These should serve as recommendations in the absence of corresponding national regulations. The relevant national laws, standards, regulations, directives and other technical provisions take priority over the German/European directives specified in this manual: The information herein is not binding for other countries and regions; as said above, they should be understood as a recommendation.

2 Product information

2.1 Standards and regulations

The following standards and regulations apply to Germany / Europe and are provided as a support feature.

Regulations from section: Sealing

Scope / Notice	Regulations applicable in Germany
Stress class of the underground, as well as suitable bonded sealing	Leitfaden zur Abdichtung im Verbund (AIV)
Approved bonded sealings with proof of practicability in keeping with building law for stress classes A and AO	ETAG 022 T1
Approved bonded sealings with proof of practicability in keeping with building law for stress classes A, B and C	DIBt-Bauregelliste A, Teil 2 des DIBt und Prüfgrundsätze für Abdichtungen im Verbund (PG AIV-F)
Permitted bonded sealings	EN 14891
Sealing of inside rooms	DIN18534

Regulations from section: Media

Scope / Notice	Regulations applicable in Germany
Typical domestic wastewater	DIN 1986-3

Regulations from section: Sound protection



Scope / Notice	Regulations applicable in Germany
Fulfilled noise protection requirements	DIN 4109
Fulfilled noise protection requirements	VDI 4100

Regulations from section: Important notes

Scope / Notice	Regulations applicable in Germany
Dimensions of slots and recesses	EN 1996

2.2 Certification

Data acc. to DIN EN 1253, Table 7

Manufacturer	Viega GmbH & Co.KG
Manufacturer identification mark	
Certificate of conformity	
Address	Viega GmbH & Co.KG Viega Platz 1 57439 Attendorn Germany
Relevant standard	DIN EN 1253-1
Load class	K3
DN	40/50
Product class with respect to temperature behaviour	A
Specific run-off behaviour	= 0.55 l/s

2.3 Intended use

2.3.1 Areas of application

The shower channel is used in the bathroom as a drain for a floor-level shower. The shower channel is designed for small to medium volumes of water, such as those occurring in the residential building sector, for example.

Technical information, see [Chapter 2.4.2 'Technical data'](#) on page 10.

2.3.2 Media

The shower channel is intended for draining common household wastewater in constant operation, see ↗ *Chapter 2.1 'Standards and regulations' on page 6.*

- The short-term temperature of the wastewater may reach up to 95° C. The temperature must be considerably lower in constant operation.
- The pH value must be higher than four but lower than ten.

It is not permitted to introduce wastewater, which could damage the product material.

2.3.3 Drainage capacity

Installation height	Water seal level	Accumulation height 10 mm	Accumulation height 20 mm
95–155 mm	50 mm	0.5 l/s	0.55 l/s

2.4 Product description

2.4.1 Overview

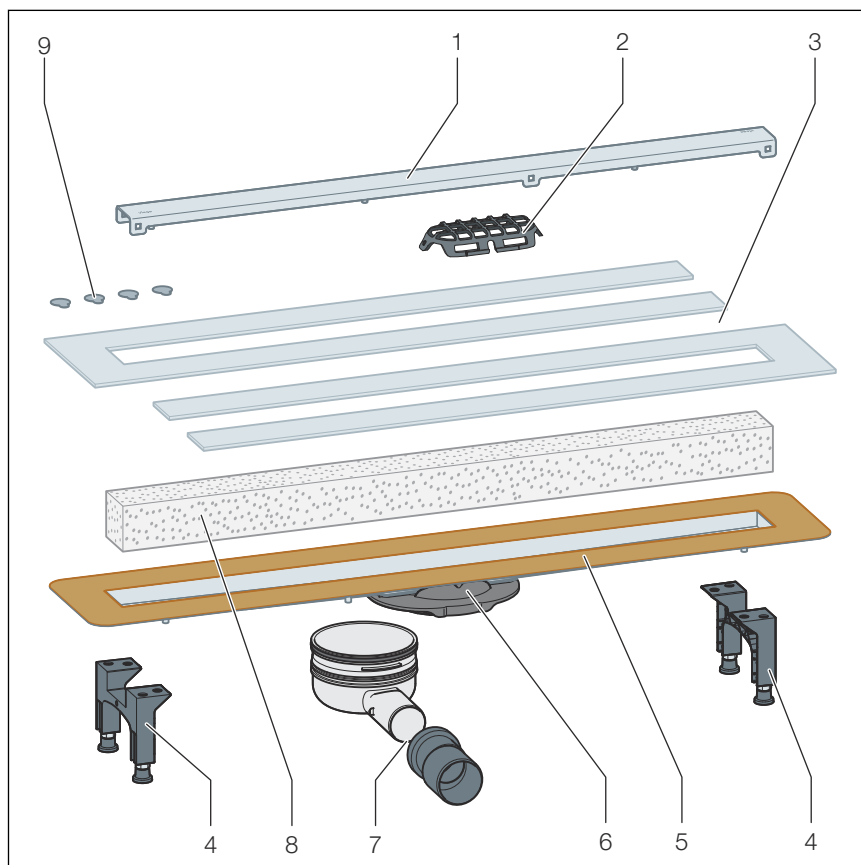

Fig. 1: Scope of delivery

- 1 Grate Visign ER10
- 2 Sieve
- 3 Building protection cardboard
- 4 Adjustable feet
- 5 Sealing flange
- 6 Connection element
- 7 Odour trap with reducer 40/50
- 8 Hard foam block
- 9 Adhesive points

2.4.2 Technical data

Nominal width [DN]	40/50
Material	Stainless steel 1.4301
Drainage capacity	↳ Chapter 2.3.3 'Drainage capacity' on page 8
Dimensions	↳ Chapter 3.1.2 'Installation dimensions' on page 15
Installation height	95–160 mm
Water seal level	50 mm
Load class	K = 300 kg

2.5 Information for use

2.5.1 Sealing

Bonded sealing

To protect against moisture penetration, apply sealing foils, which are to be processed in liquid state, directly below the tiles on screed and walls. The determination of the stress class and the underground as well as the selection of the suitable bonded sealing must be carried out in compliance with the valid standards and regulations, see: ↳ Chapter 2.1 'Standards and regulations' on page 6.

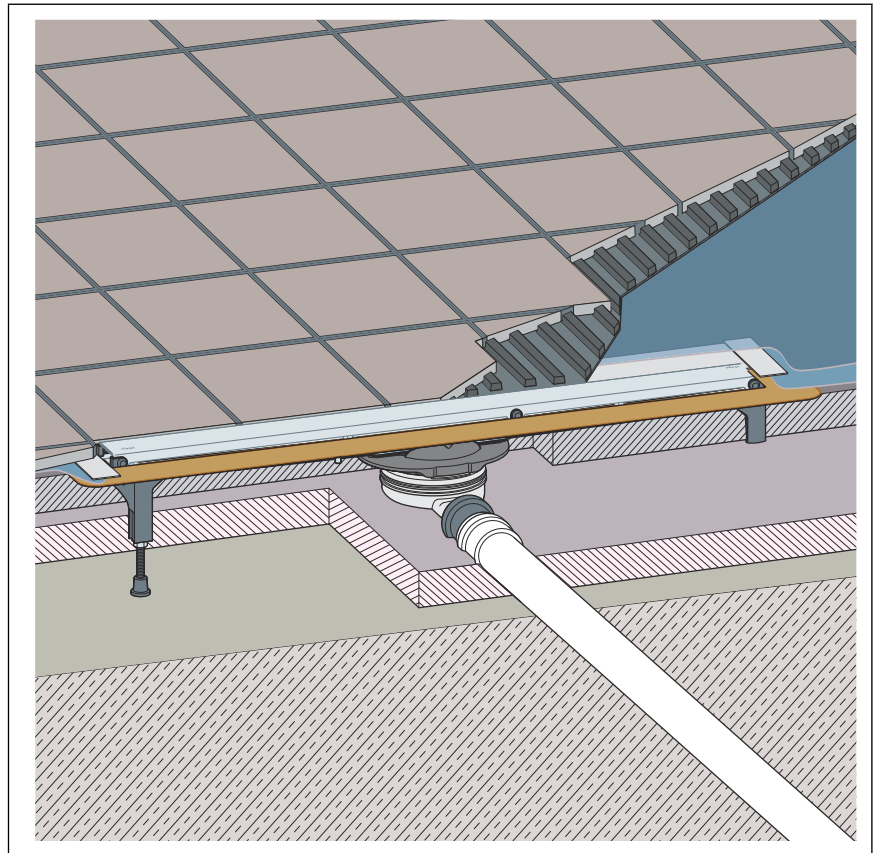

Fig. 2: Diagram of a bonded seal

Important note

Careful planning is required for sealing. In addition, depending on the individual dampness wear class and the type of foundation, a suitable thin bed bonded sealing with a building regulations certificate of suitability must be chosen.

Furthermore, the following factors should be taken into account:

- The drain or shower channel must be equipped with a special flange, which has an adhesive surface and a width of at least 50 mm.
- For bridging the material change from drain to screed, either a suitable sealing collar or sealing tape designed for overlapping with the thin bed bonded sealing over a width of at least 50 mm must be used.
- The screed must be laid at a minimum incline of 1–2%.
- The installation must be carried out in acc. with the mounting instructions and the manufacturer's information.

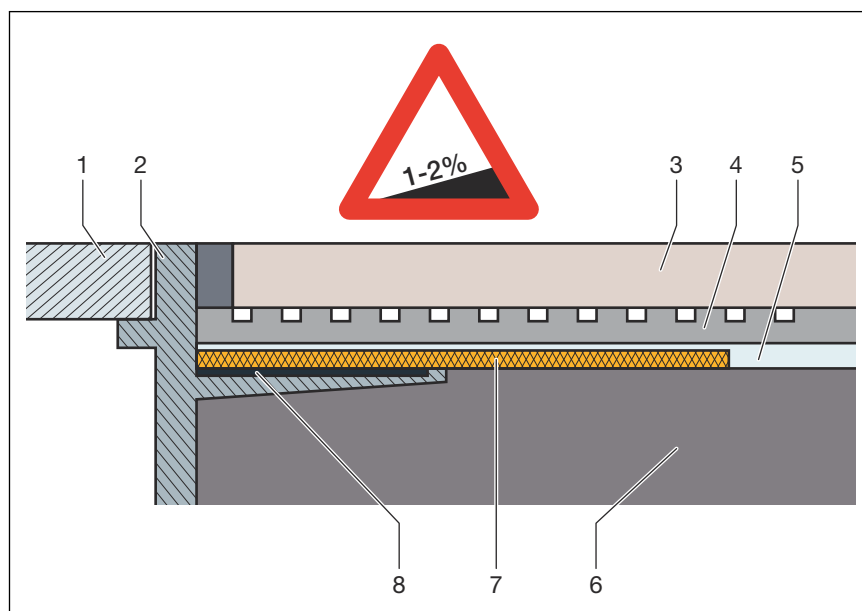

Fig. 3: Construction diagram of the bonded seal - min. screed incline 1–2 %

- 1 Grate
- 2 Top piece with adhesive flange
- 3 Tile
- 4 Tile cement
- 5 Bonded sealing
- 6 Screed
- 7 Sealing collar
- 8 Adhesive

Permitted bonded seals

In connection with suitable drains, only approved bonded sealings with proof of practicability in keeping with building law may be used. See [Chapter 2.1 'Standards and regulations'](#) on page 6.

Information regarding the procedure can be found in the instructions for use of the corresponding product.

2.5.2 Fire protection

Advantix shower channels and drains can both be fitted to be fire proof. The R120 pipe lead-in can be used for this purpose in the floor construction. In this way, a fire resistance time of up to 120 minutes can be achieved.

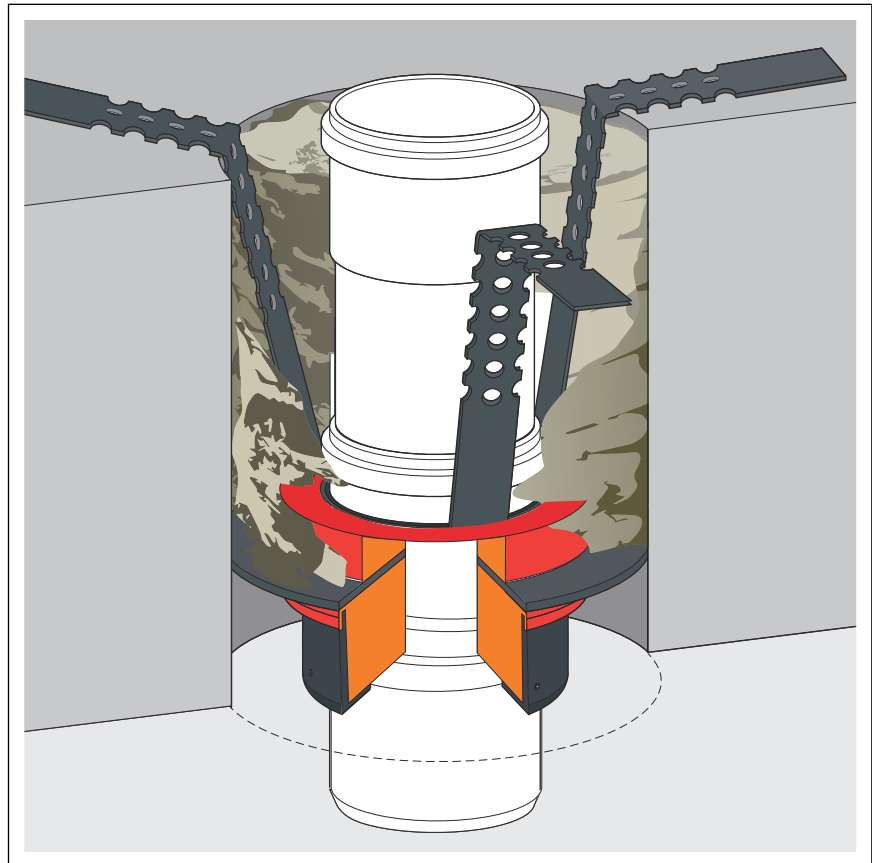

Fig. 4: Example: fire protection pipe lead-in

For mounting instructions for the R120 pipe lead-in see model 4923.5, art. no. 491 673.

2.6 Required accessories

The following parts are not included in the scope of delivery and can be ordered separately:

- Sealing tape for Advantix shower channels, model 4964.95, art. no. 619 121
- If required: mounting adhesive, model 4938.22, art. no. 571 788

3 Assembly

3.1 Assembly information

3.1.1 Important note

Before assembly:

- Check if the drainage capacity of the model chosen is sufficient for the arising water volume ↪ *Chapter 2.3.3 'Drainage capacity' on page 8.*
- An adequate level of floor covering stability must be guaranteed ↪ *Chapter 2.4.2 'Technical data' on page 10.* This can be achieved either through an adequate screed thickness or another alternative solution. Relevant measures must be considered before mounting.
- The dimensions of slots and recesses must be in compliance with the regulations from section ↪ *'Regulations from section: Important notes' on page 6.*

During assembly:

- Observe installation dimensions.
- Do not use mounting adhesive older than 18 months.
- Position the shower channel in such a way that the grate is removable.

After assembly:

- The sealing accessories should be given to the person responsible for the bonded sealing (e.g. tiler).
- Coordinate all relevant installation details, especially regarding the bonded sealing, with those responsible for the subsequent work.

3.1.2 Installation dimensions

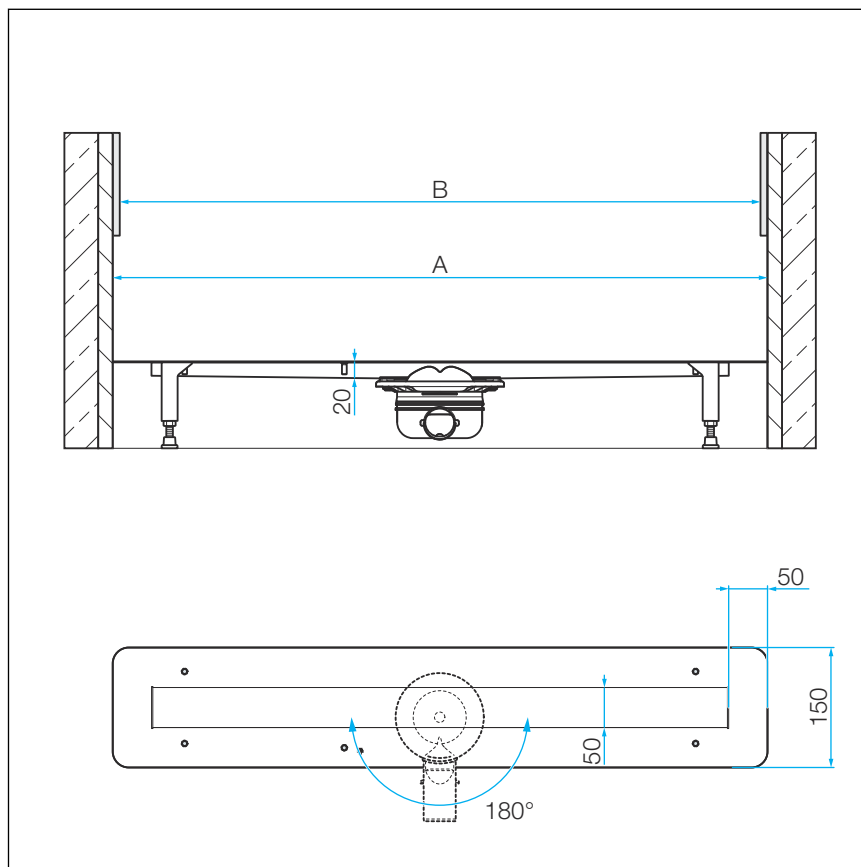

Fig. 5: Niche dimensions

Art. no.	A ¹⁾	B ²⁾	Standard dimension of shower door
753 153	770	670	750
753 160	820	720	800
753 177	920	820	900
753 184	1020	920	1000
753 191	1220	1120	1200

¹⁾ linear dimension of the base unit

²⁾ inner dimension of the base unit (grate size)

3.1.3 Tools and materials

Special tools

- Fork spanner size 8 for grate mounting
- Tool for the removal of the grate (e.g. model 4965.90, art. no. 689 704)

3.2 Determine height

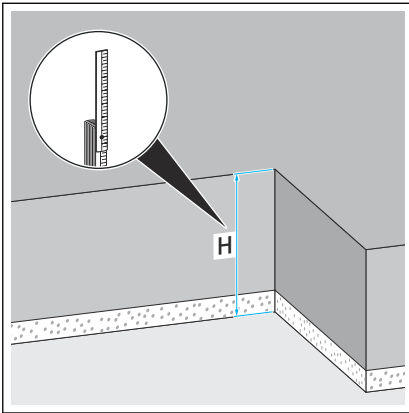

► Determine installation height (H).

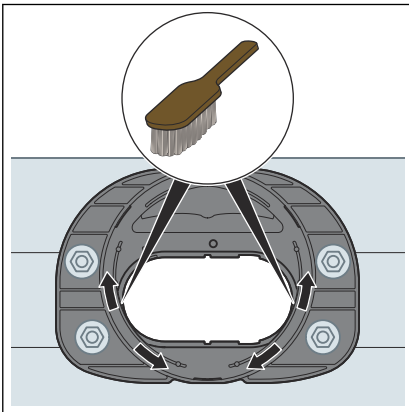

► Check the connection element for soiling, clean if necessary.

3.3 Mounting base unit

Mounting the drain

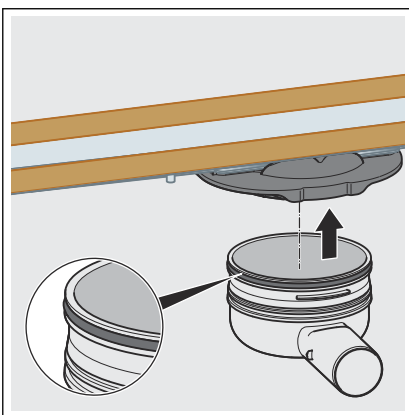

► Insert the greased sealing element into the casing.
Observe the sealing element is correctly in place (see arrow).

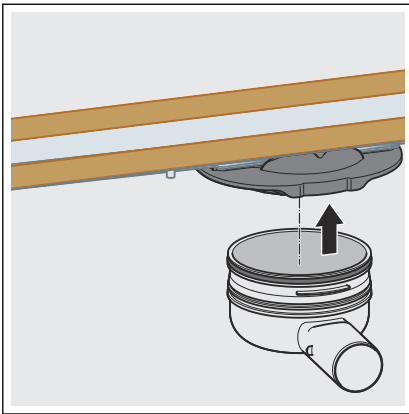

- Press the drain straight into the connection element until it snaps home.

Mounting the adjusting feet and drain sockets

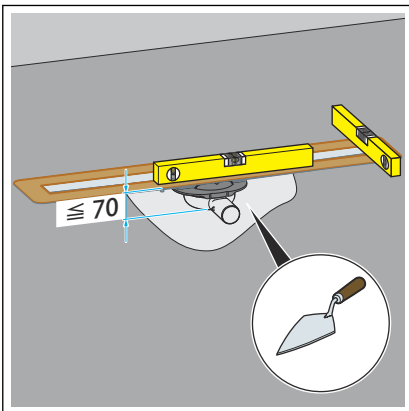

- For installation heights of up to 70 mm:
Align the base unit in the mortar bed.

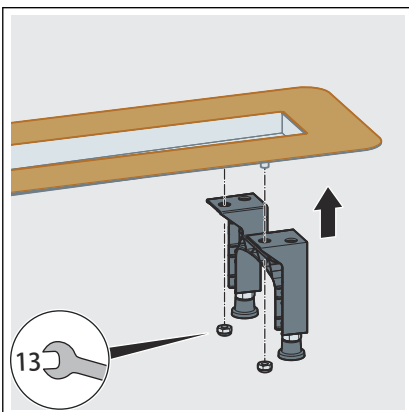

- Mount the adjusting feet.
Regarding mounting, refer to the instructions for use for the adjusting feet set.

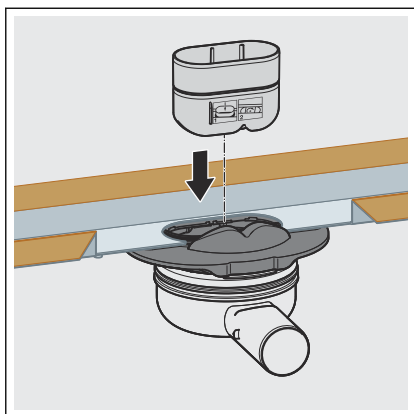

► Put in the odour trap insert.

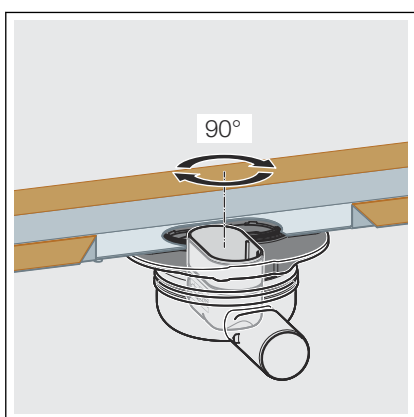

► Turn the odour trap insert clockwise through 90°.

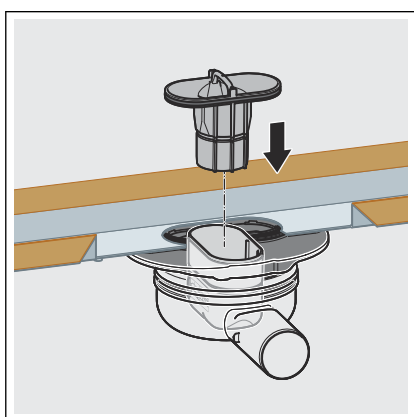

► Insert the immersion pipe of the odour trap.

◻ Inserting the immersion pipe of the odour trap fastens the odour trap insert.

3.4 Aligning shower channel

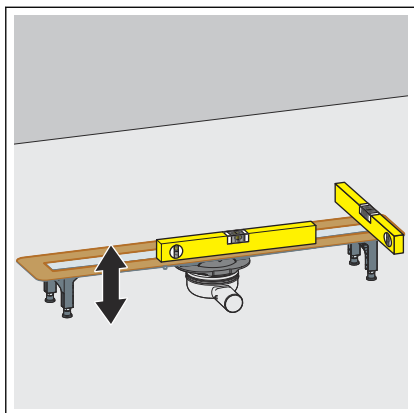

- Adapt the base unit to screed height by adjusting the feet.
- Align the base unit horizontally in all directions.

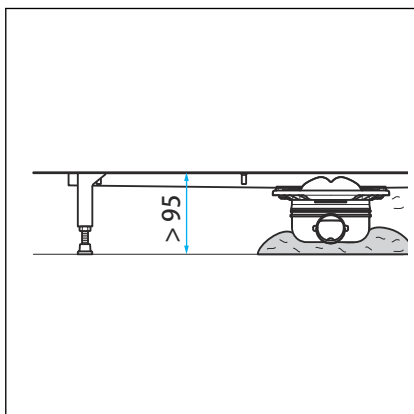

- With an installation height above 95 mm, provide the odour trap with mortar bedding to prevent slippage.

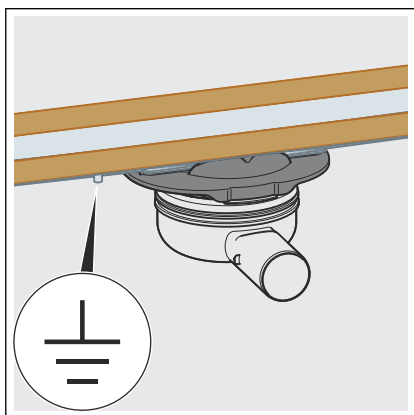

- Check whether grounding is required.

3.5 Connecting shower channel

The connection to the wastewater system must be completed before the drain can be installed in the floor construction.

Requirements:

- A pipe to the planned drainage position is already in place for the connection to the wastewater system.
- The drainpipe has an internal profile seal.

Proceed as follows:

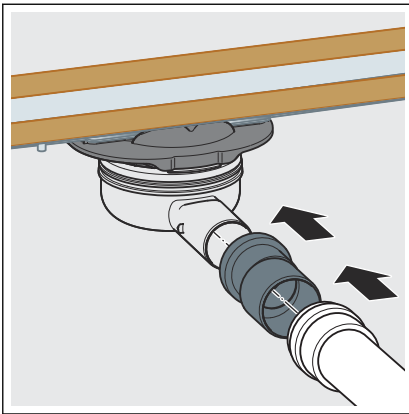

- Put the reducer and the drainpipe fully onto the drain socket.

3.6 Preparing for further work

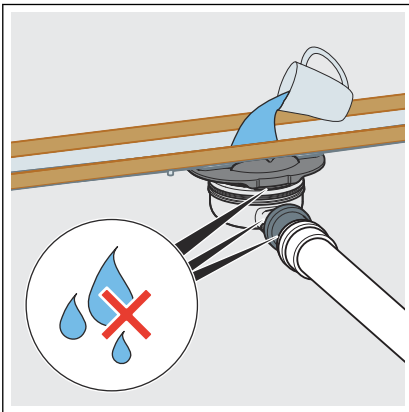

- Fill the shower channel with water.
- Check the drain casing and pipeline for leak tightness.

Lining with screed



NOTICE! **Product damage due to improper installation**

If cavities form during the lining of the shower channel, leaks may occur when pressure is applied.

Inform the subsequent workers that the shower channel must be fully lined and that there must be no cavities generated.

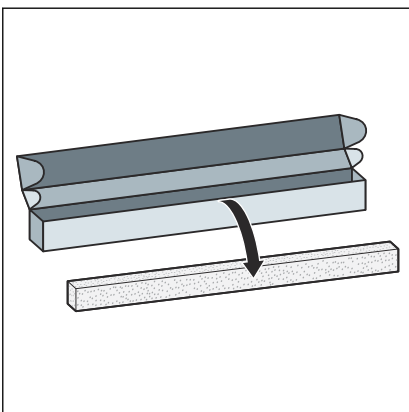

- Remove the hard foam block from the packaging.

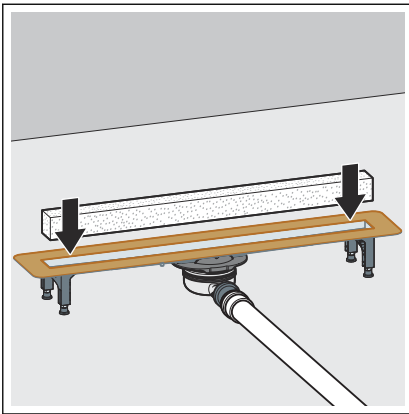

- Insert the protective insert made of hard foam.

The protective insert acts as a mounting aid and protection against contamination.

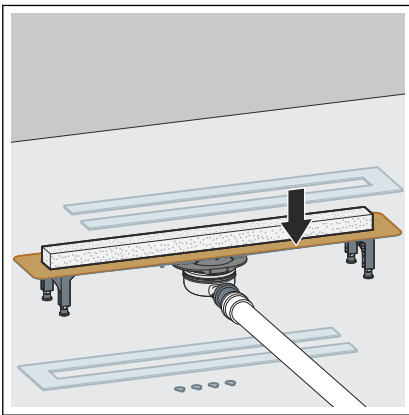

- Mount the site protection.

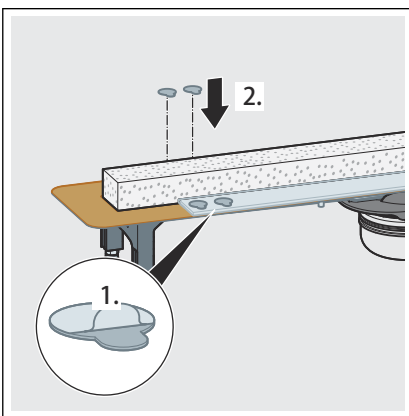

- Stick on the adhesive points and remove the protective cover.

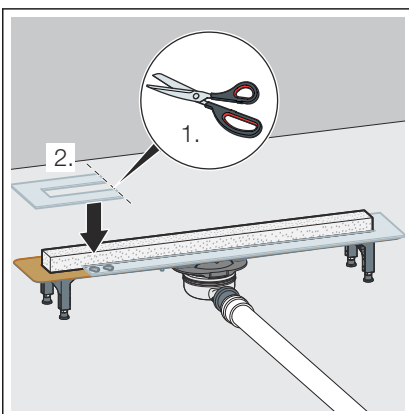

- Shorten the second part of the site protection if applicable, and mount it.

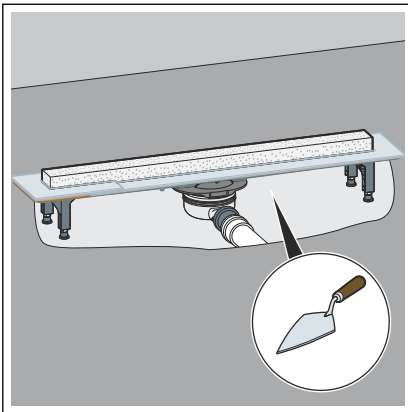

INFO! Screed and floor tiles must be laid at an incline of 1–2 % in the direction of the shower channel.

- Line the shower channel fully with screed up to the upper edge of the flange.

3.7 Sealing the shower channel

Requirements

The flange must be clean and free from material residue. If necessary, clean the flange.



The sealing tape is not included with delivery. Viega recommends model 4964.95, art. no. 619 121.

Sealing can take place with or without the use of mounting adhesive. The mounting adhesive is not included in the scope of delivery. Viega recommends model 4938.33, art. no. 571 788.

Sealing with bonded sealing, without mounting adhesive

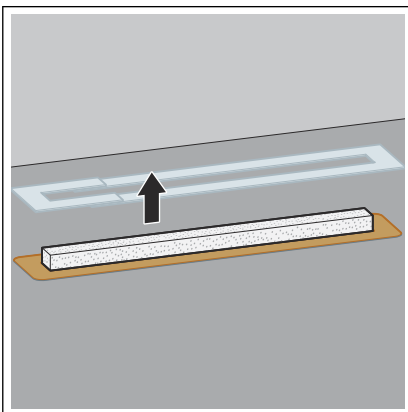

- Remove the site protection.

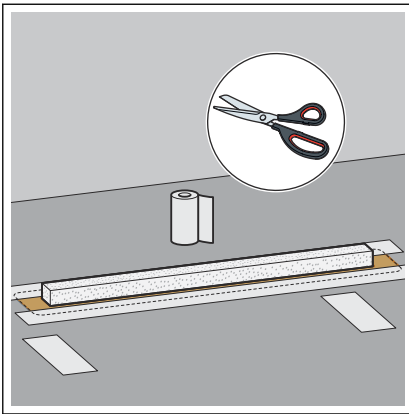

- Cut the sealing tape generously. The strips must overlap when stuck on.

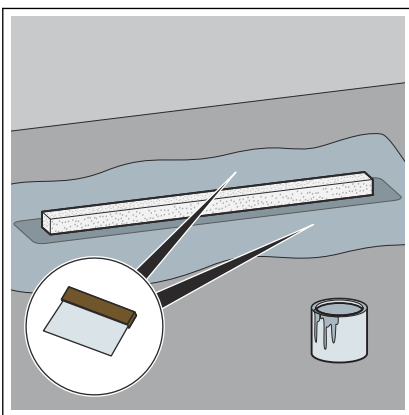

- Apply the first layer of bonded sealing generously onto the screed and the flange. Observe the instructions for use of the manufacturer of the bonded sealing.

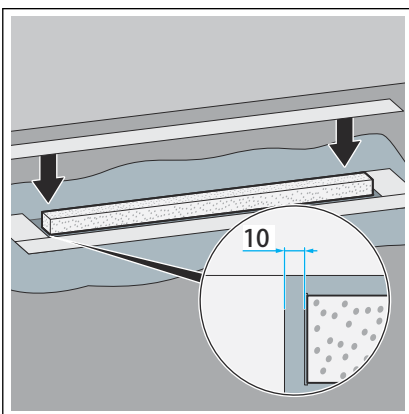

- Place the sealing tape on the flange in such a way that flange and screed are evenly covered.
- Press the sealing tape firmly into the bonded sealing. Overlap the corners in the process.

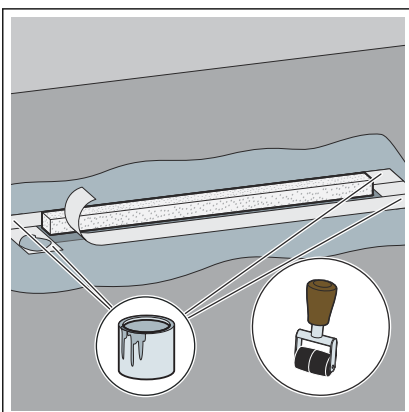

- Stick the overlapping tape strips together at the corners with bonded sealing.
- Thoroughly work over the adhesive surfaces with a roller.

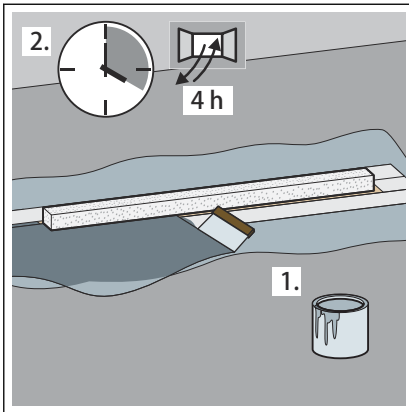

► Apply the second layer of bonded sealing generously on the sealing tape and screed.

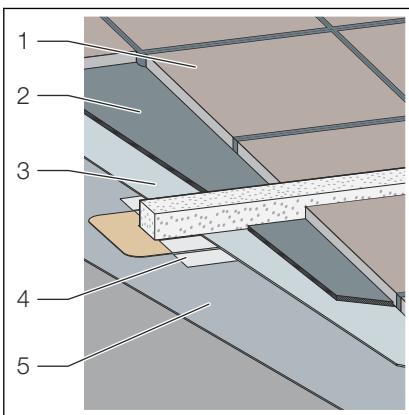

► Layer build-up sealing:

- 1 – Tiles
- 2 - Tile adhesive
- 3 – Bonded sealing (2)
- 4 - Sealing tape
- 5 – Bonded sealing (1)

If no cover trim is to be fitted, the floor can now be tiled ↪ *Chapter 3.8 'Installation in tiled floors' on page 27.*

Sealing with bonded sealing and mounting adhesive

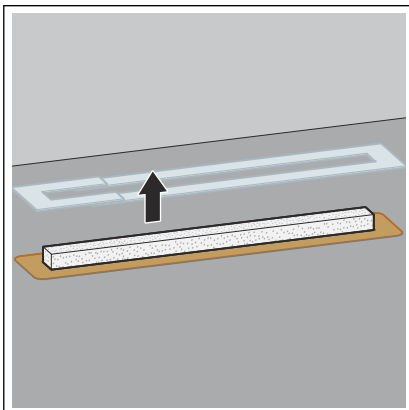

► Remove the site protection.

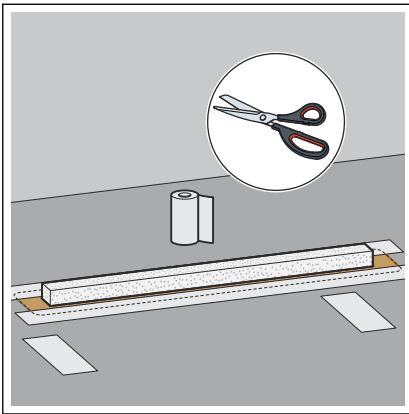

- Cut the sealing tape to length so that the tape overlaps the flange and the screed.

Ensure that they overlap by at least 50 mm!

The sealing tape must enclose the entire shower channel.

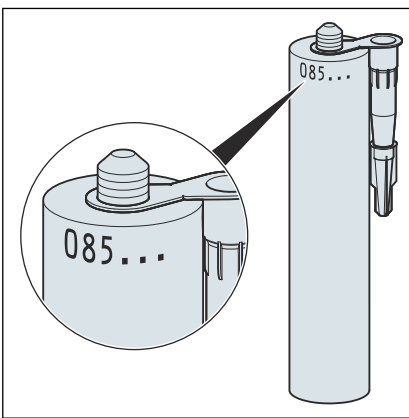

- Use a suitable tool to open the cartridge of the mounting adhesive.

INFO! Check the expiry date on the cartridge.

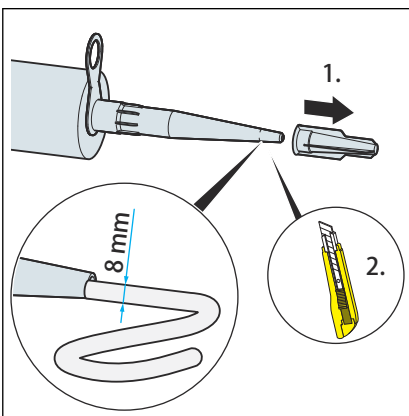

- Unscrew the cartridge and cut it so that you can apply the adhesive in a strip of approx. 8 mm width.

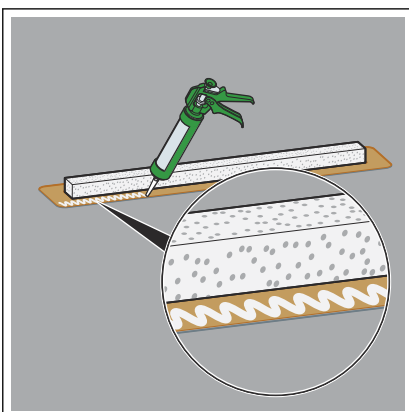

- Apply the mounting adhesive to the flange.

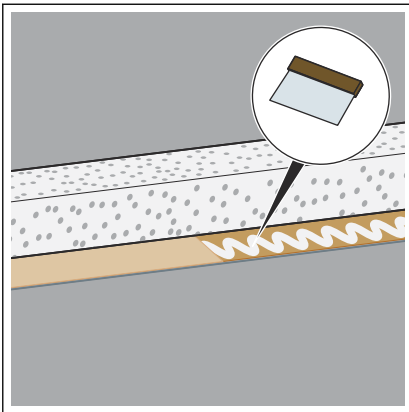

- Use a palette-knife to spread the mounting adhesive evenly.

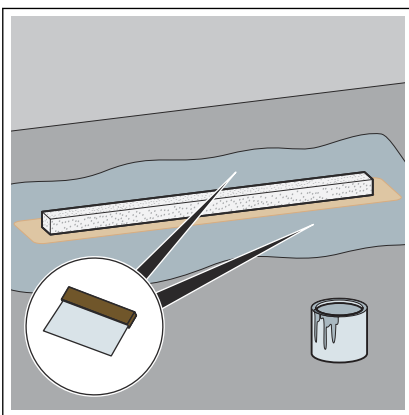

- Apply the first layer of bonded sealing generously onto the screed. Observe the instructions for use of the manufacturer of the bonded sealing.

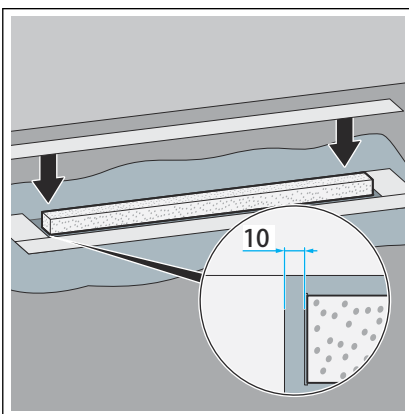

- Place the sealing tape on the flange in such a way that flange and screed are evenly covered.
- Press the sealing tape firmly onto the mounting adhesive and the bonded sealing. Overlap the corners in the process.

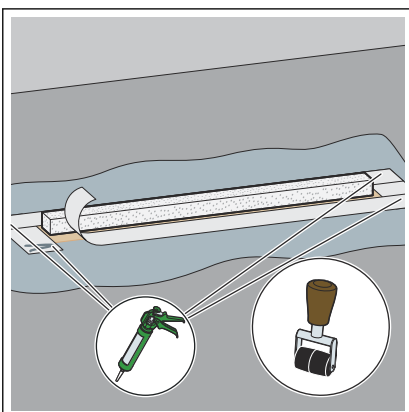

- Stick the overlapping strips together at the corners with mounting adhesive.
- Thoroughly work over the adhesive surface with a roller.

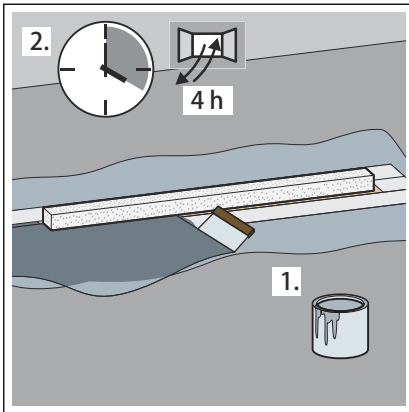

- Apply the second layer of bonded sealing generously on the sealing tape and screed.

If no cover trim is to be fitted, the floor can now be tiled ↪ *Chapter 3.8 'Installation in tiled floors' on page 27.*

3.8 Installation in tiled floors

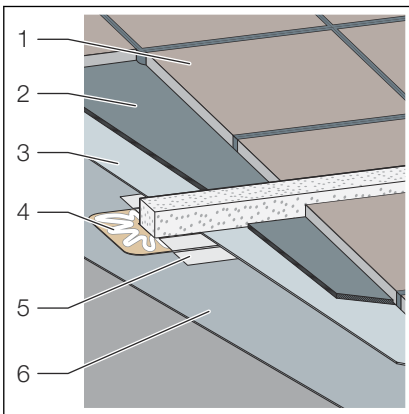

- Layer build-up sealing:
 - 1 – Tiles
 - 2 - Tile adhesive
 - 3 – Bonded sealing (2)
 - 4 – Mounting adhesive
 - 5 - Sealing tape
 - 6 – Bonded sealing (1)

Mounting with Viega mounting frames

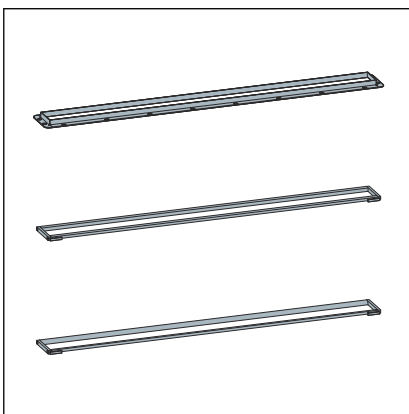

- Regarding mounting, refer to the instructions for use for the mounting frame.

- Model 4982.30
- Model 4982.40
- Model 4982.45

Installation with covering

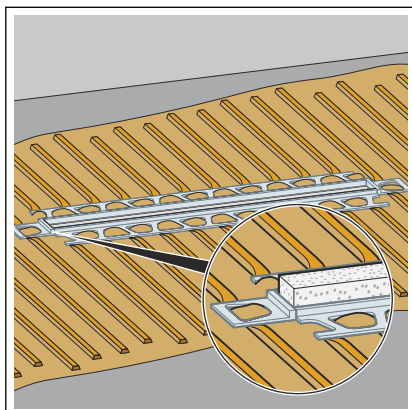

- Glue the rail in a straight line at the protective insert.
- Deburr the cutting edges.
- Avoid differences in height between different parts of the strip.
 - The shower channel is now installed.

The floor can now be tiled ↗ 'Lay tiles (mounting without cover trim)' on page 28.

Lay tiles (mounting without cover trim)

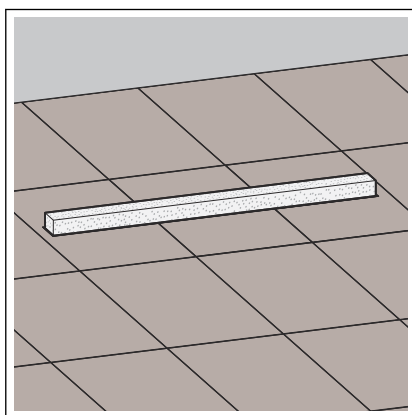

- Lay the tiles right up to the edge of the protective insert.
- CAUTION!** Avoid sharp edges in the following places in the barefoot area:
- on tiles
 - at surface ends
 - on mounting profiles
- Polish the tile edge.

Mounting the grate

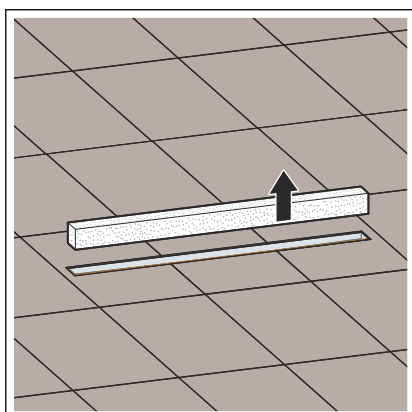

- Remove the hard foam block.

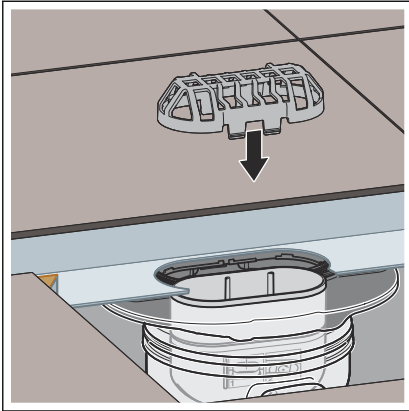

► Insert the sieve.

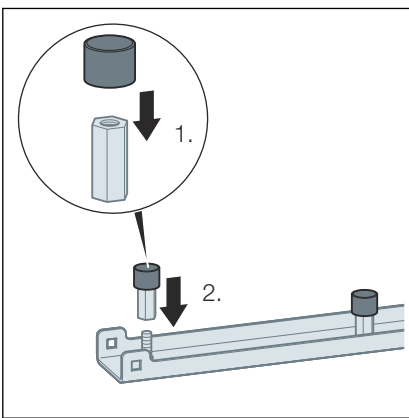

► Screw the threaded feet onto the threaded pins.
The threaded feet are used to adjust the height of the grate.

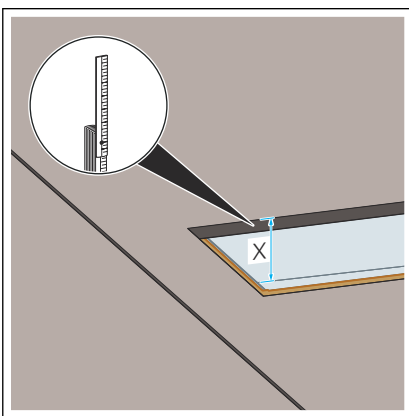

► Calculate dimension X to the upper edge of the tiles.
Always measure at the channel end.

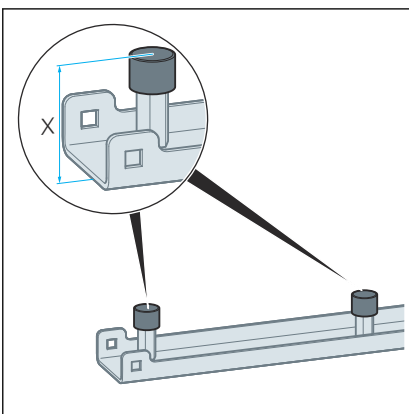

► Adjust the threaded bolt to dimension X.

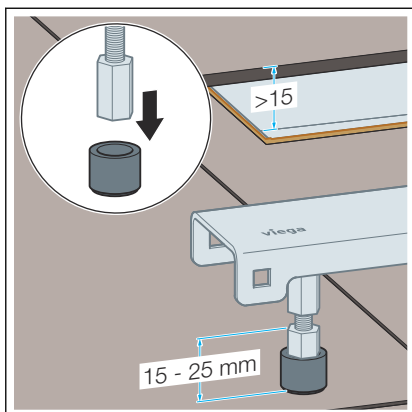

- If necessary, insert the extension screws.
- Remove the rubber plugs on the height adjustments.
- Screw in the extension screws.
- Place the rubber plugs on the extension screws.
- Adjust the extension screws to the height of the finished floor.

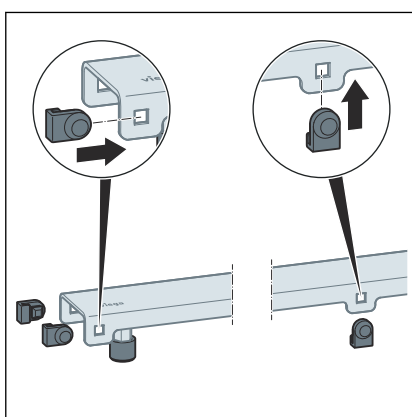

- Insert spacers.

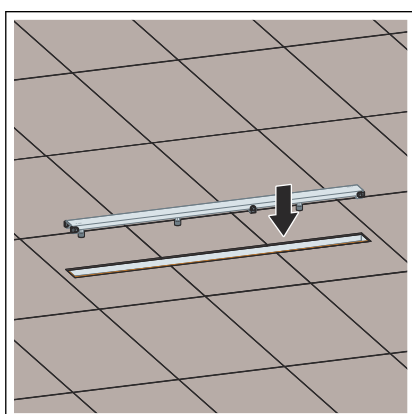

- Insert the grate.

3.9 Installation in self-levelling coating



Have the work on the self-levelling coating carried out by specialist companies trained for the respective product. Ask the respective manufacturer about the suitability of comparable products.

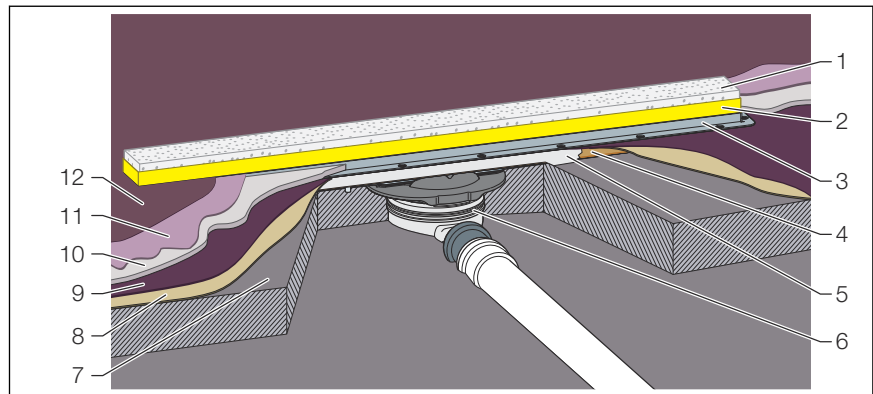
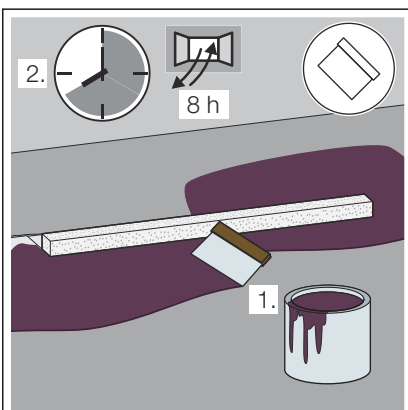
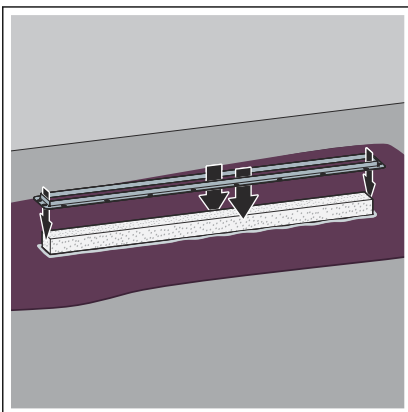

Fig. 6: Layer structure of the self-levelling coating

- 1 Site protection
- 2 Adhesive tape (optional) to prevent the site protection from sticking to the polystyrene
- 3 stainless steel frame
- 4 Stainless steel channel body with epoxy sanding
- 5 Sealing tape
- 6 drain casing
- 7 Screed
- 8 Bonded sealing
- 9 Primer on screed
- 10 Scraper filler / PU sealing also as height adjustment
- 11 Self-levelling coating / design floor
- 12 Sealing / slip resistance

- Apply the bonded sealing with the first coat of primer.
- Place the stainless-steel frame (e.g. model 4982.45).



- After the primer has dried, apply the scratch coat or PU sealing to the primed bonded sealing for height adjustment.
- Apply the self-levelling coating or the design floor.
- Optionally apply a sealing / slip-resistant coating.

Mounting the grate

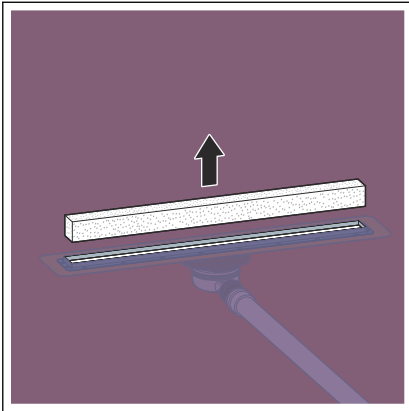

- Remove the hard foam block.

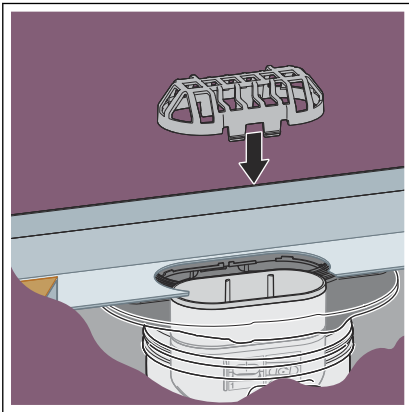

- Insert the sieve.

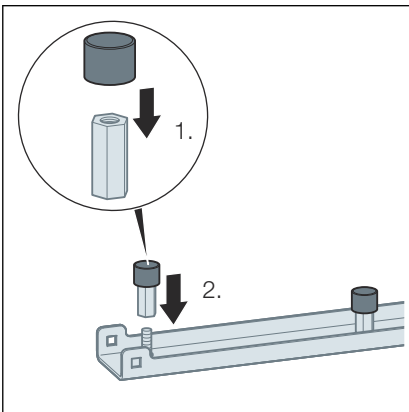

- Screw the threaded feet onto the threaded pins.
The threaded feet are used to adjust the height of the grate.

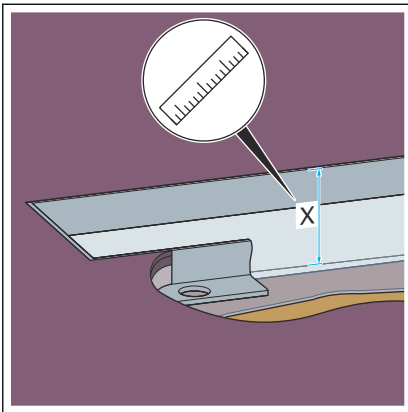

- Determine dimension X, which extends to the upper edge of the self-levelling coating.

Always measure at the channel end.

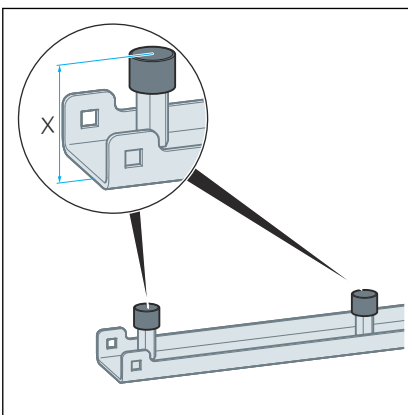

- Adjust the threaded bolt to dimension X.

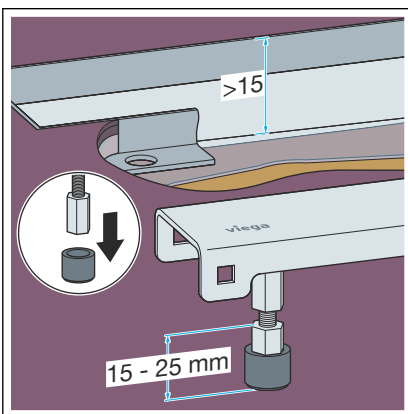

- If necessary, insert the extension screws.
- Remove the rubber plugs on the height adjustments.
- Screw in the extension screws.
- Place the rubber plugs on the extension screws.
- Adjust the extension screws to the height of the finished floor.

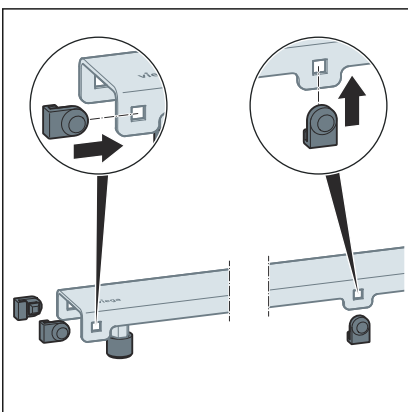

- Insert spacers.

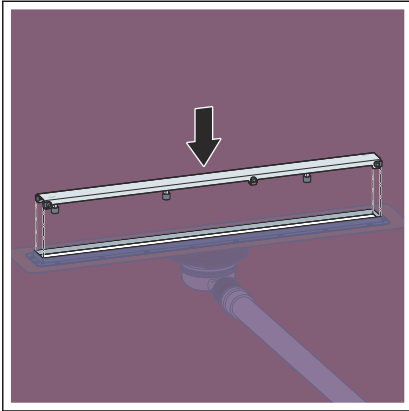

► Insert the grate.

4 Care

4.1 Care tips

Normal soap or a mild cleaning agent can be used for regular maintenance and prevention of lime scale on the grate and frame. Use no scouring agent or abrasive objects.

Strong stains, even around the drain unit and the odour trap, can be removed using typical household cleaner. Rinse the detergent very thoroughly with clear water after the prescribed dwell time. There should be no residue on the components.

4.2 Cleaning

Viega recommends using a mild cleaning agent, a cloth and a washing-up brush for cleaning.

Cleaning the drain

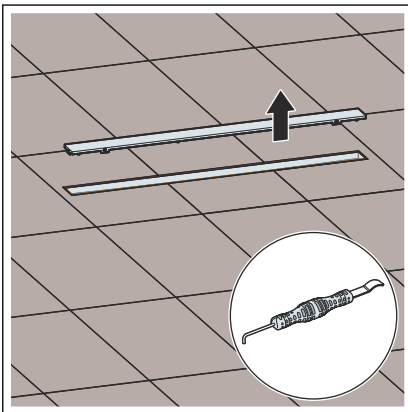

- Remove the grate, for example with the removal tool model 4965.90, art. no. 689 704.

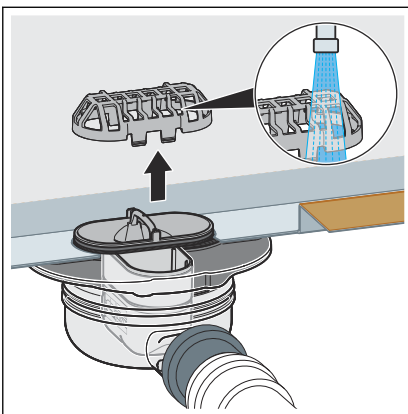

- Remove the sieve and clean it under running water.

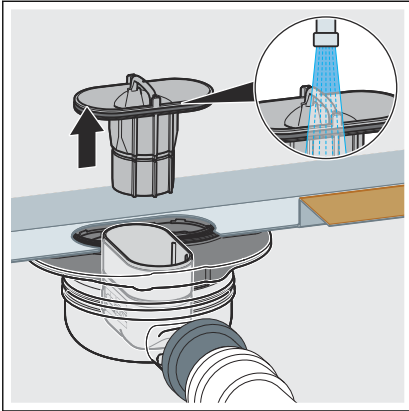

- Remove the immersion pipe of the odour trap.
- Clean the sieve and immersion pipe.

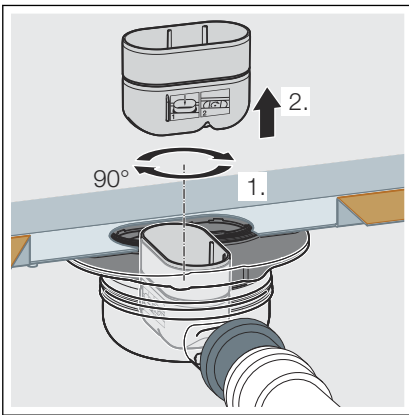

- Remove the odour trap insert.

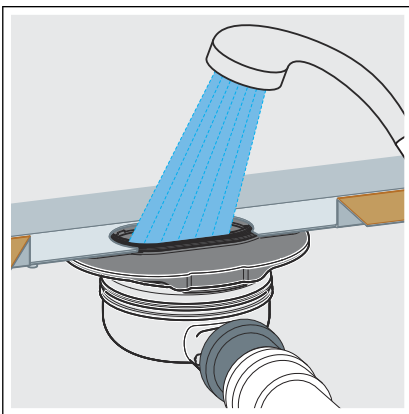

- Clean the base unit.

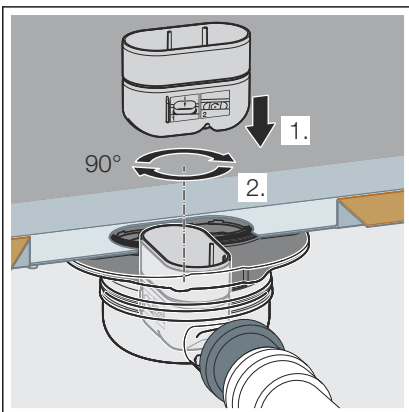

- Replace the odour trap insert.

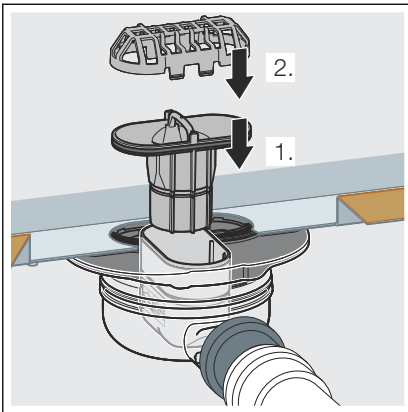

- Replace the immersion pipe.
- Replace the sieve.
- Replace the grate.

Clean shower channel

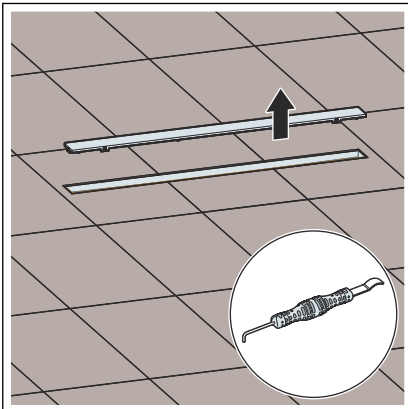

- Remove the grate, for example with the removal tool model 4965.90, art. no. 689 704.

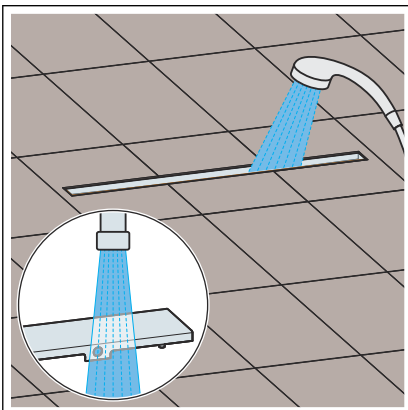

- Clean the grate and shower channel.
- Rinse with clean water.

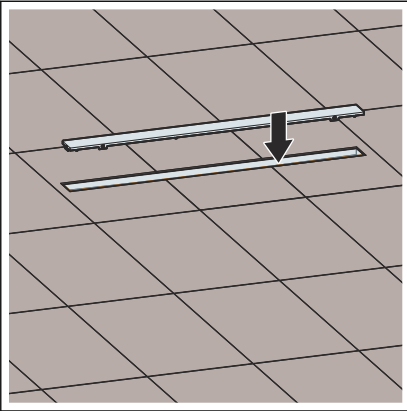

► Replace the grate in the shower channel.

5 Disposal

Separate the product and packaging materials (e. g. paper, metal, plastic or non-ferrous metals) and dispose of in accordance with valid national legal requirements.



Viega GmbH & Co. KG
service-technik@viega.de
viega.com

INT • 2024-07 • VPN230382

