

Instructions for Use

Geopress K gas flow monitor type R with SC-Contur

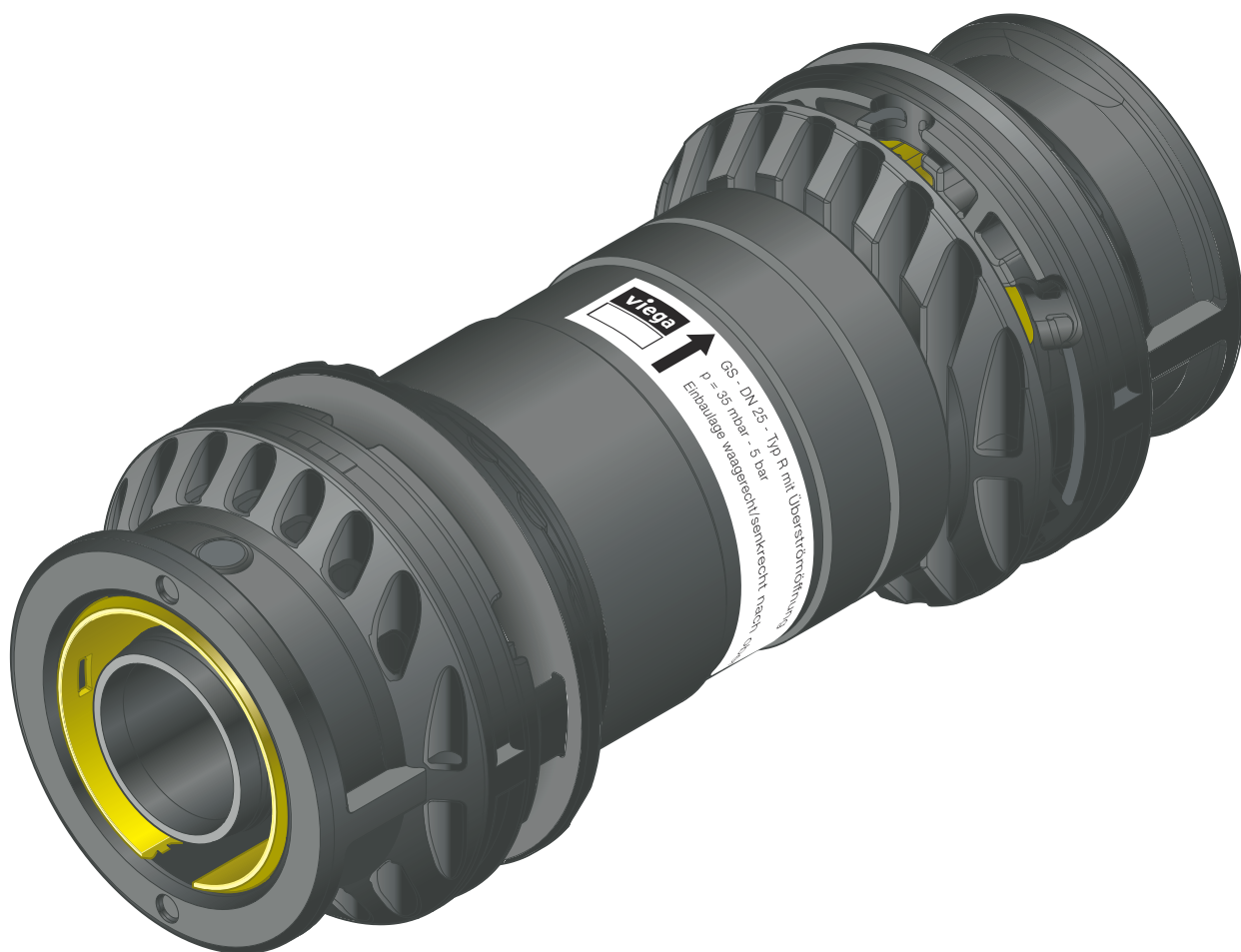

for shutting off the flow of gas when the gas flow volume exceeds a prescribed value due to an unintended release of gas

Model
9752.1

Year built (from)
01/2023

viega

Table of contents

1	About these instructions for use	3
	1.1 Target groups	3
	1.2 Labelling of notes	3
	1.3 About this translated version	4
2	Product information	5
	2.1 Standards and regulations	5
	2.2 Intended use	7
	2.2.1 Areas of application	7
	2.2.2 Media	7
	2.3 Product description	8
	2.3.1 Overview	8
	2.3.2 Pipes	8
	2.3.3 Press connectors	8
	2.3.4 Markings on components	9
	2.3.5 Operating mode	9
	2.3.6 Technical data	10
	2.4 Information for use	11
	2.4.1 Corrosion	11
3	Handling	12
	3.1 Storage	12
	3.2 Assembly information	12
	3.2.1 Mounting instructions	12
	3.2.2 Required tools	13
	3.3 Assembly	13
	3.3.1 Cutting pipes to length	13
	3.3.2 Deburring the pipes	14
	3.3.3 Pressing the connection	15
	3.3.4 Leakage test	18
	3.4 Disposal	18

1 About these instructions for use

Trade mark rights exist for this document; for further information, go to viega.com/legal.

1.1 Target groups

The information in this manual is directed at utility and pipeline construction companies and their technical professionals.

Only specialist companies which can prove they are qualified in accordance with the applicable directives may be engaged for the construction of gas house service connections, see ↗ *'Regulations from section: Target groups'* on page 5.

The installation of Viega products must take place in accordance with the general rules of engineering and the Viega instructions for use.

1.2 Labelling of notes

Warning and advisory texts are set aside from the remainder of the text and are labelled with the relevant pictographs.



DANGER!

This symbol warns of possible life-threatening injury.



WARNING!

This symbol warns of possible serious injury.



CAUTION!

This symbol warns of possible injury.



NOTICE!

This symbol warns of possible damage to property.



This symbol gives additional information and hints.

1.3 About this translated version

This instruction for use contains important information about the choice of product or system, assembly and commissioning as well as intended use and, if required, maintenance measures. The information about the products, their properties and application technology are based on the current standards in Europe (e.g. EN) and/or in Germany (e.g. DIN/DVGW).

Some passages in the text may refer to technical codes in Europe/Germany. These should serve as recommendations in the absence of corresponding national regulations. The relevant national laws, standards, regulations, directives and other technical provisions take priority over the German/European directives specified in this manual: The information herein is not binding for other countries and regions; as said above, they should be understood as a recommendation.

2 Product information

2.1 Standards and regulations

The following standards and regulations apply to Germany / Europe and are provided as a support feature.

Regulations from section: Target groups

Scope / Notice	Regulations applicable in Germany
Qualification of specialist companies	DVGW-Arbeitsblatt GW 301

Regulations from section: Application areas

Scope / Notice	Regulations applicable in Germany
Planning, execution, modification and operation of liquid gas installations	DVFG-TRF 2021
Planning, execution, modification and operation of gas house service connections	DVGW-Arbeitsblatt G 459-1
Gas transportation / gas distribution pressure testing procedure	DVGW-Arbeitsblatt G 469
Gas supply lines made of plastic pipe – installation	DVGW-Arbeitsblatt G 472

Regulations from section: Media

Scope / Notice	Regulations applicable in Germany
Gas, hydrogen and liquid gas in the gaseous state	DVGW-Arbeitsblatt G 260

Regulations from section: Pipes

Scope / Notice	Regulations applicable in Germany
Permitted use with piping materials (PE 80 / 100 / 100 RC)	DIN 8074
Permitted use with piping materials (PE 80 / 100 / 100 RC)	DIN 8075
Permitted pipe types (PE-X)	DIN 16893
Permitted pipe types (PE-X)	DIN 16892

Regulations from section: Technical data

Scope / Notice	Regulations applicable in Germany
Basis for the technical inspection	DIN 30652-2

Regulations from section: Corrosion

Scope / Notice	Regulations applicable in Germany
Corrosion protection	DIN 30672
Corrosion protection for external pipes	DVGW-TRGI 2018
Corrosion protection for external pipes	DVFG-TRF 2021,, Point 7.3.1.2

Regulations from section: Notes on mounting

Scope / Notice	Regulations applicable in Germany
Threshold values for ovalities	DIN EN 1555-2, Table 1

Regulations from section: Leakage test

Scope / Notice	Regulations applicable in Germany
Leakage test of gas household connection installations	DVGW-Arbeitsblatt G 459-1
Leakage test of gas household connection installations	DVGW-Arbeitsblatt G 469

2.2 Intended use



Agree the use of the model for areas of application and media other than those described with Viega.

The system can be applied at outdoor temperatures from -10 °C to 50 °C. The component temperatures of the press connectors and the press machine must not be less than -5 °C.

2.2.1 Areas of application

The gas flow monitor is suitable for use in gas house service connections. As an active protective measure, the gas flow monitor interrupts the gas supply of the connection line in case of accident.

Gas installation

For planning, execution, modification and operation of gas house service connections, observe the applicable regulations, see ↗ *'Regulations from section: Application areas'* on page 5.

2.2.2 Media

The model is suitable for the following media, see ↗ *'Regulations from section: Media'* on page 5.

- Gas
- Liquid gas in the gaseous state



Coordinate the use of the gas flow monitor with hydrogen with the Viega Service Centre.

The max. operating pressure depends on the type of pipe used and the specific application.

- Operating pressure $p_{\max} = 1.0 \text{ MPa}$ (10 bar)
(with open gas flow monitor)

The maximum load of the closed gas flow monitor is 0.6 MPa (6 bar).

2.3 Product description

2.3.1 Overview

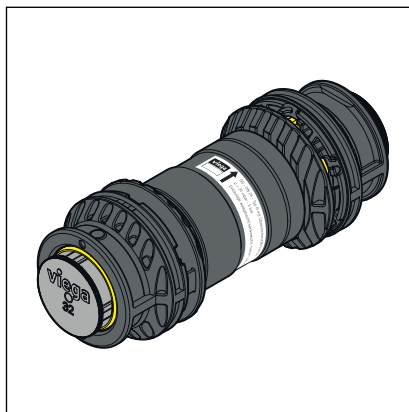

Fig. 1: 9752.1

The model is available in the following dimensions: d32 / 40 / 50 / 63.

2.3.2 Pipes

The gas flow monitor can be used with the following pipes:

d [mm]	PE80, PE100, PE100 RC ¹⁾	PE-X ¹⁾
	SDR 11	SDR 11
32	✓	✓
40	✓	✓
50	✓	✓
63	✓	✓

¹⁾ see ↗ 'Regulations from section: Pipes' on page 6

2.3.3 Press connectors

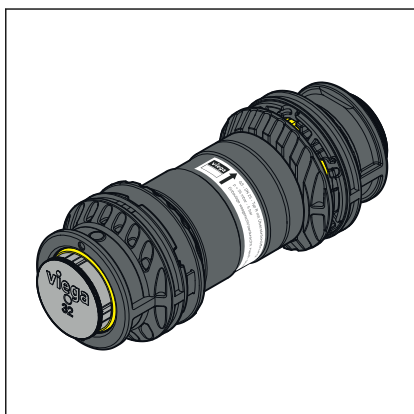

Fig. 2: 9752.1

The gas flow monitor is integrated into a Geopress K gas press connector. The press connector can be directly pressed onto the pipe.

The press connectors have a support sleeve with a 5-tooth sealing contour on it. Part of this sealing contour is a circumferential bead in which an HNBR sealing element is inserted. During pressing, the pipe is pressed onto the sealing contour and sealed from the inside so that the press connector is permanently attached to the pipe. Geopress K Gas press connectors are equipped with a yellow clamping ring made of POM for a longitudinal force resistant connection. The press connectors have a window for checking the insertion depth..

SC-Contur

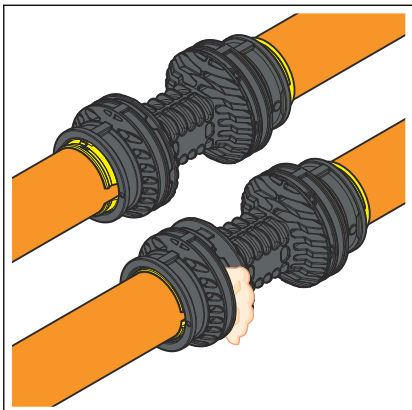
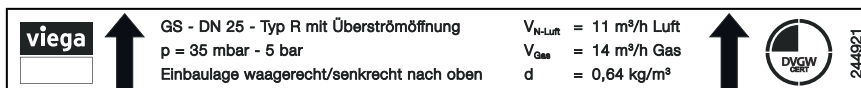

Fig. 3: SC-Contur

Viega press connectors are equipped with the SC-Contur. SC-Contur is a safety mechanism certified by the DVGW and ensures that the press connector leaks in an unpressed state. In this way, inadvertently unpressed connections are noticed during a leakage test.

Viega guarantees that unpressed connections become visible during a leakage test:

2.3.4 Markings on components



A sticker with the specifications is applied to the gas flow monitor. The installation direction is shown by an arrow. The installation direction must be observed to ensure the functionality of the gas flow monitor.

The yellow dot shows that the press connector is equipped with the SC-Contur and that the connector is suitable for gas.

The traceability code on the press connector allows every press connector to be traced back and simplifies the documentation in as-completed drawings.

2.3.5 Operating mode

Gas flow monitor (GFM)

Geopress K gas flow monitors are flow-activating fittings and serve as an active protective measure against the uncontrolled escape of gas in the case of a damaged gas service connection.

- The gas flow monitor consists of a closing plate, which is held open during intended operation use by a spring force determined by type. The gas flow monitor therefore has a defined flow direction.
- In the case of a fault, the flow volume and the pressure behind the gas flow monitor change so that the spring force is no longer sufficient to hold the GFM open. The closing plate sits in its valve seat and closes the pipe. A further release of gas is prevented.
- The gas flow monitor is equipped with an overflow opening. It therefore opens automatically after a fault has been repaired. The opening process can be accelerated by applying gas counterpressure.

2.3.6 Technical data

Geopress K gas flow monitors comply with the technical test regulation in accordance with the applicable regulations, see ↗ *Chapter 2.1 'Standards and regulations' on page 5.*

Operating pressure range GFM type R

Operating pressure range and building requirement	Place of installation	Construction size
0.0035–0.5 MPa (0.035–5 bar) DN related $\Delta p \leq 5.25 \text{ hPa}$ (5.25 mbar) Overflow volume $\leq 30 \text{ dm}^3/\text{h}$ with 0.1 MPa (1 bar)	Beginning HSC	up to DN 50 [d _a 63]

In its delivery state, the gas flow monitor is preset for the operating pressure range of the respective type. On-site setting is not necessary.

Flow and pressure loss values GFM type R

Nominal width [DN]	Nominal volume flow [m ³ /h air]	Nominal volume flow [m ³ /h gas]	Δp
25 [d _a 32]	11	14	2.10 hPa (2.10 mbar)
32 [d _a 40]	16	21	2.10 hPa (2.10 mbar)
40 [d _a 50]	24	31	2.50 hPa (2.50 mbar)
50 [d _a 63]	34	44	2.50 hPa (2.50 mbar)

Guide values for the protectable pipe length

Pipe length which can be protected when a gas flow monitor pursuant to the applicable regulations is used, see ↗ *Chapter 2.1 'Standards and regulations' on page 5.*

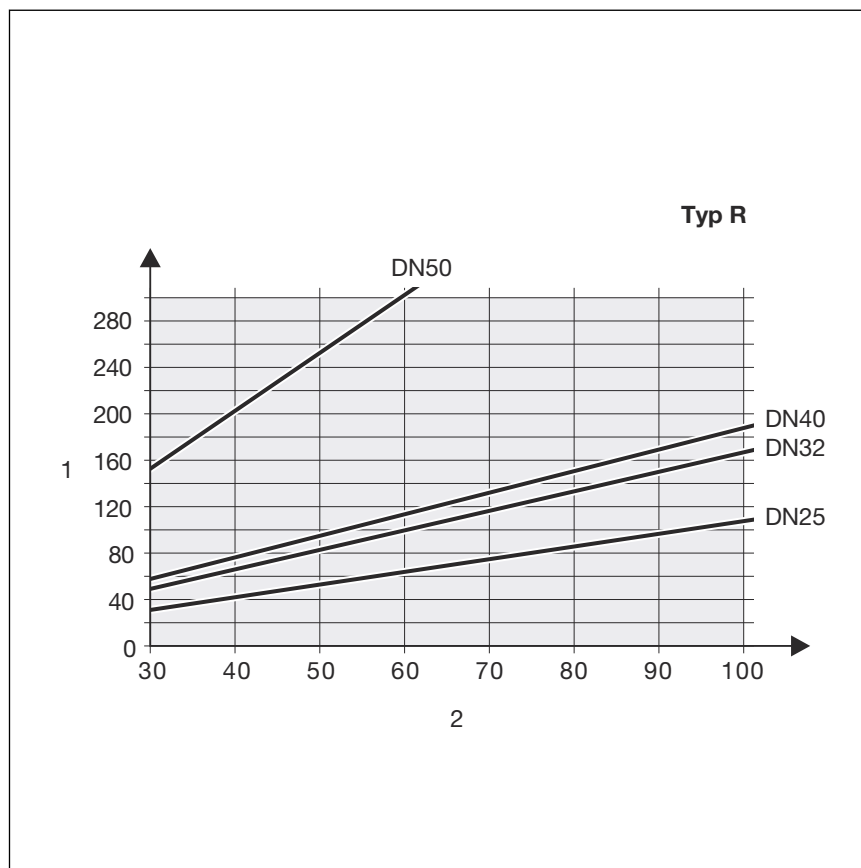

Fig. 4: Guide values for resistance coefficient $\zeta=10$ for the tapping valve and the main shut-off device

- 1 - Length (m)
- 2 - Mains system pressure (hPa)

2.4 Information for use

2.4.1 Corrosion

Due to a lower probability of corrosion in the case of laying in the ground and in contact with ground and surface waters with pH-values between 6 and 8, corrosion protection is not required in the case of press connectors with metal components. Soils containing ammoniac require corrosion protection in acc. with the pertinent guidelines, see [Chapter 2.1 'Standards and regulations'](#) on page 5.

Only components and supplies (e. g. sealant) that have been awarded a DVGW test symbol may be used.

3 Handling

3.1 Storage



Leave the gas flow monitor in the original packaging until use so that sensitive components do not become contaminated.

3.2 Assembly information

3.2.1 Mounting instructions

Geopress K gas flow monitor:

- Install in the immediate vicinity of the tapping valve.
- Installation position horizontally or vertically upwards
- Check that the gas flow monitor is suitably designed for the application before installing.
- Observe installation direction.
- Excessive use of lubricants can impair the function.

Checking system components

System components may, in some cases, have become damaged through transportation and storage.

- Check all parts.
- Replace damaged components.
- Do not repair damaged components.

Pipes must be visually inspected for the following damage before installation:

- Ovalities: threshold values must not be exceeded, see [↗ 'Regulations from section: Notes on mounting' on page 6.](#)
- Dents
- Cracks
- Grooves on the exterior
- Scoring on the inside (not permissible)
- damaged pipe ends

Check scope of delivery

The following components must be included:

- Gas flow monitor
- Sticker "Specifications"

- Information sign "Main shut-off device"
- Cable tie

3.2.2 Required tools

The following tools are required for mounting the gas flow monitor:

- Pipe cutter, pipe shear or saw
- Deburrer and coloured pen for marking
- Battery-powered press machine
- Hinged adapter jaw model 2296.2
 - Z2 with 32–63 mm diameter
- Press ring model 9796.1



Viega recommends the use of Viega system tools when installing the press fittings.

The Viega system press tools have been developed and tailored specifically for the installation of Viega press connector systems.

3.3 Assembly

3.3.1 Cutting pipes to length

For information about tools, also see [Chapter 3.2.2 'Required tools'](#) on page 13.

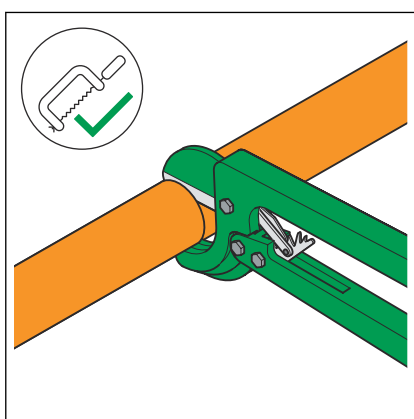
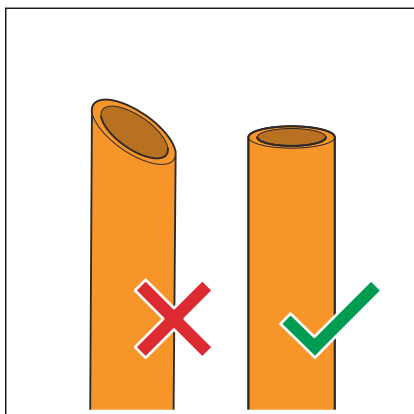

- ▶ Cut the pipe to length at a right angle as accurately as possible using pipe shears, a pipe cutter or a saw to ensure correct and even pipe insertion depth.

3.3.2 Deburring the pipes

If a burr appears when the pipes are cut, then the pipe ends must be carefully deburred on the inside and outside.

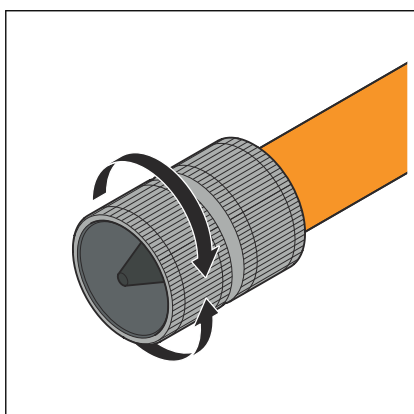

- ▶ Deburr the inside and outside of the pipe.
- ▶ When using protective coated pipe, remove the protective coating according to the manufacturer's instructions.

3.3.3 Pressing the connection

Requirements:

- The pipe end is not bent or damaged.
- The protective coating of the protective coated pipe is removed.
- The pipe is deburred.
- Check the internal and external pipe surfaces for contamination, and clean them as required. Remove any shavings.

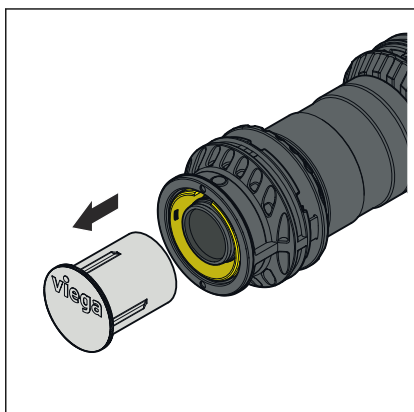
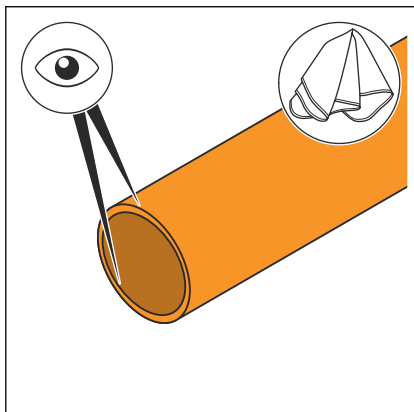

- Remove the protective cap immediately before fitting the pipe and protect the connection against dirt ingress.

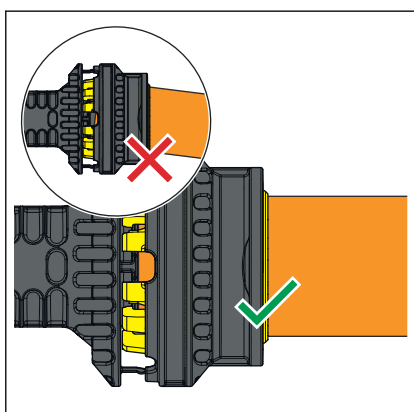

- To avoid damaging the sealing element, push the press connector straight onto the pipe without twisting.

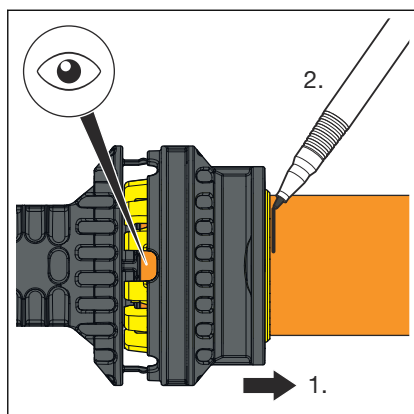

- Check the insertion depth in the inspection window and mark it.

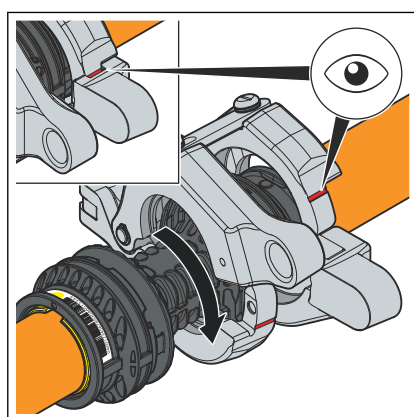

- Open the press ring and check for dirt and function.
 - Place the press ring around the press connector.
- Observe the press connector side and pipe side of the press ring.
The press ring is properly closed when the red marking can no longer be seen.

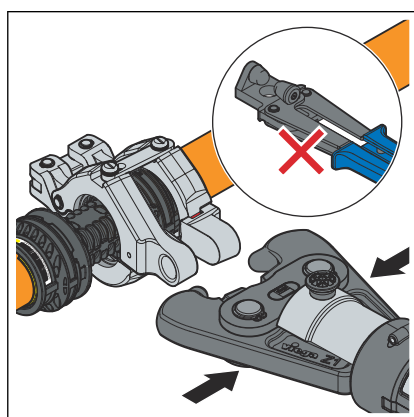

- Open the hinged adapter jaw and latch it into the press ring holder.

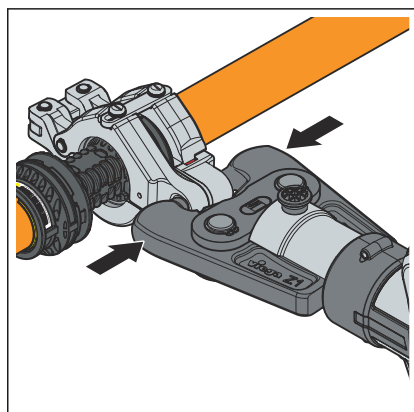

- Carry out the pressing.

NOTICE!

The press ring must close completely during pressing.

- Make sure there is adequate space at the pressing point.
- Keep the press contour and the area around the pressing point clean.

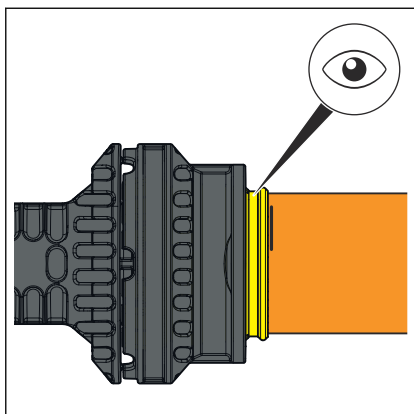

- The clamping ring is easily recognised after successful pressing.
- ◻ The connection is marked as having been pressed.
- Check the insertion depth.

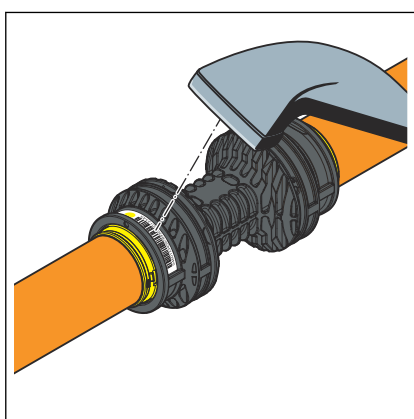

- Scan in the traceability code.

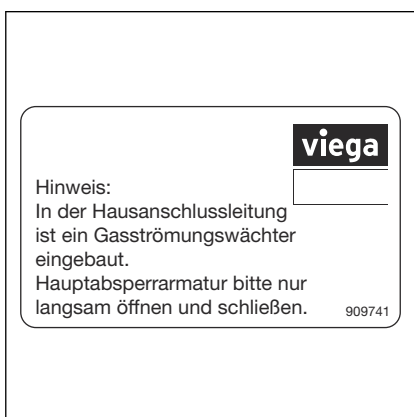

- Attach the information sign to the main shut-off device.

viega

Hinweis:
 In der Hausanschlussleitung
 ist ein Gasströmungswächter
 eingebaut.
 Hauptabsperrarmatur bitte nur
 langsam öffnen und schließen. 909741

3.3.4 Leakage test

Perform a leakage test according to the applicable regulations before commissioning the connection line, see ↗ *'Regulations from section: Leakage test'* on page 6.

Carry out the test on a service connection that is finished but not yet covered. The result of the leakage test must be documented as proof of the safety of the pipeline.



- The testing air must flow in slowly upstream to the gas flow monitor so that it does not close.
- Testing opened gas flow monitors with air is permitted up to a maximum pressure of 1.0 MPa (10 bar).
- The closed gas flow monitor may only be subjected to pressures of a maximum of 0.6 MPa (6 bar).

3.4 Disposal

Separate the product and packaging materials (e. g. paper, metal, plastic or non-ferrous metals) and dispose of in accordance with valid national legal requirements.



Viega GmbH & Co. KG
service-technik@viega.de
viega.com

INT • 2024-07 • VPN240071

