

Instructions for Use

Advantix shower channel grate Visign ER12



For inserting surface of tiles or natural stone at any height

Model
4982.71

Year built (from)
04/2016

viega

Table of contents

1	About these instructions for use	3
	1.1 Target groups	3
	1.2 Labelling of notes	3
	1.3 About this translated version	4
	1.4 Other applicable documents	4
2	Product information	5
	2.1 Certification	5
	2.2 Intended use	5
	2.2.1 Areas of use	5
	2.3 Product description	6
	2.3.1 Overview	6
3	Handling	7
	3.1 Assembly information	7
	3.1.1 Installation dimensions	7
	3.2 Assembly	8
	3.2.1 Mounting the grate	8
	3.2.2 Care	11
	3.3 Disposal	11

1 About these instructions for use

Trade mark rights exist for this document; for further information, go to viega.com/legal.

1.1 Target groups

The information in this instruction manual is directed at the following groups of people:

- Heating and sanitary professionals and trained personnel

Individuals without the abovementioned training or qualification are not permitted to mount, install and, if required, maintain this product. This restriction does not extend to possible operating instructions.

The installation of Viega products must take place in accordance with the general rules of engineering and the Viega instructions for use.

1.2 Labelling of notes

Warning and advisory texts are set aside from the remainder of the text and are labelled with the relevant pictographs.



DANGER!

This symbol warns of possible life-threatening injury.



WARNING!

This symbol warns of possible serious injury.



CAUTION!

This symbol warns of possible injury.



NOTICE!

This symbol warns of possible damage to property.



This symbol gives additional information and hints.

1.3 About this translated version

This instruction for use contains important information about the choice of product or system, assembly and commissioning as well as intended use and, if required, maintenance measures. The information about the products, their properties and application technology are based on the current standards in Europe (e.g. EN) and/or in Germany (e.g. DIN/DVGW).

Some passages in the text may refer to technical codes in Europe/Germany. These should serve as recommendations in the absence of corresponding national regulations. The relevant national laws, standards, regulations, directives and other technical provisions take priority over the German/European directives specified in this manual: The information herein is not binding for other countries and regions; as said above, they should be understood as a recommendation.

1.4 Other applicable documents

This instruction for use describes the mounting of an accessory set for an Advantix Vario shower channel in rough steps.





The instructions for use of the Advantix Vario shower channel must also be strictly observed for the mounting of the accessory set.

2 Product information

2.1 Certification

Data acc. to DIN EN 1253, Table 7

manufacturer	Viega Holding GmbH & Co.KG
manufacturer identification mark	
Certificate of conformity	
Address	Viega Technology GmbH & Co.KG Viega Platz 1 57439 Attendorn Germany
Relevant standard	DIN EN 1253-2
Load class	K3
Product class with respect to temperature behaviour	A

2.2 Intended use

2.2.1 Areas of use

The Advantix grate Visign is suitable for use in Viega Advantix shower channels base unit model 4981.10 and model 4982.20. Only wastewater commonly encountered in households may be introduced.

2.3 Product description

2.3.1 Overview

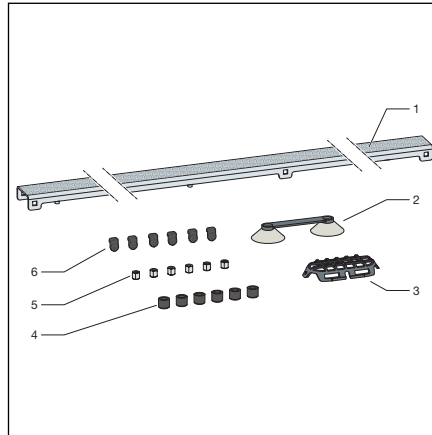

Fig. 1: Scope of delivery

- 1 Grate
- 2 Vacuum lifter
- 3 Sieve insert
- 4 Rubber cap
- 5 Threaded feet
- 6 Plug set

3 Handling

3.1 Assembly information

3.1.1 Installation dimensions

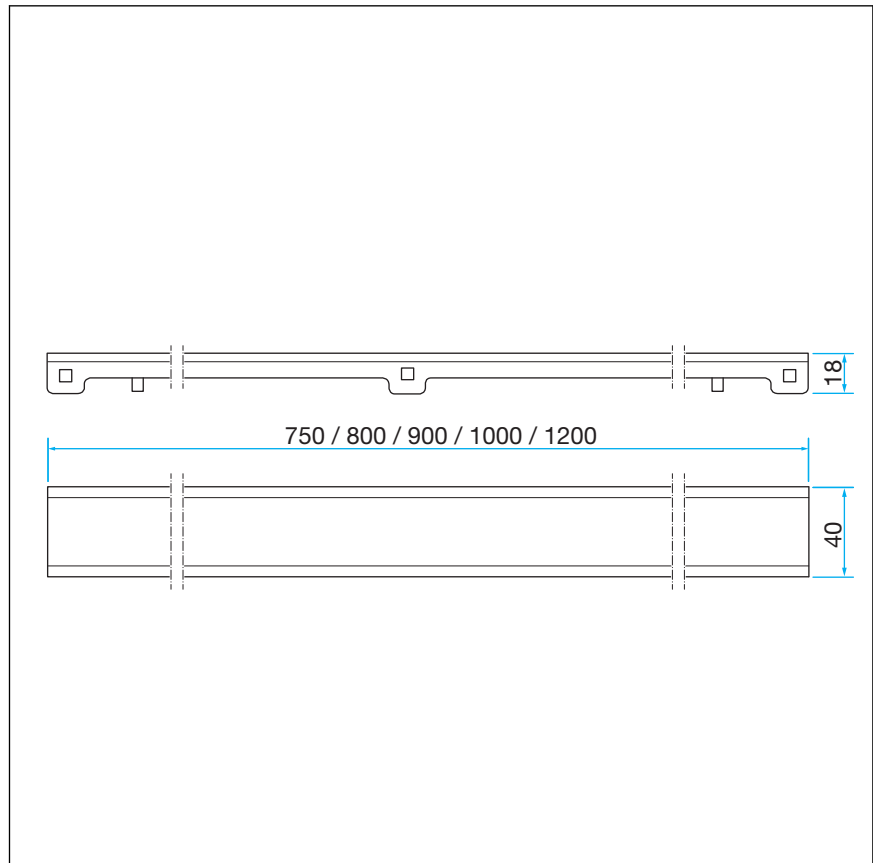
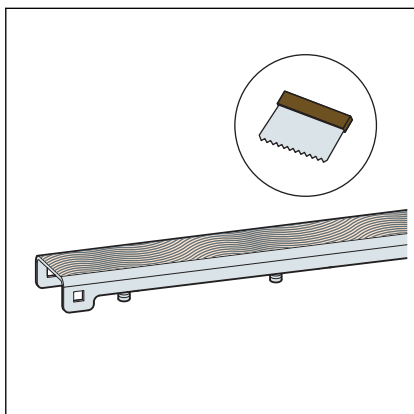

Fig. 2: Installation dimensions

3.2 Assembly

3.2.1 Mounting the grate

Preparing the grate



- Coat the grate with tile adhesive.

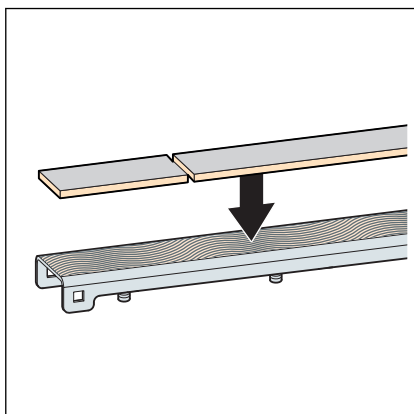

- Press the cut out tiles into the tile adhesive and align parallel to the grate.

If necessary, polish the tile edges (deburr).

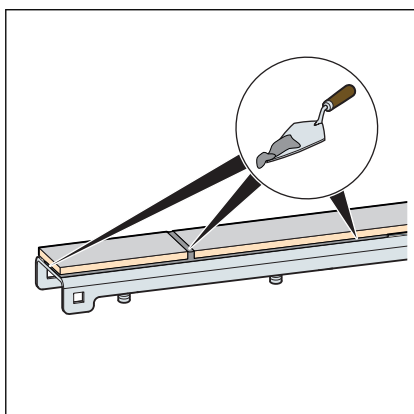

- Close the gap between the tile surface and the stainless steel grate with tile adhesive.

Mounting the grate

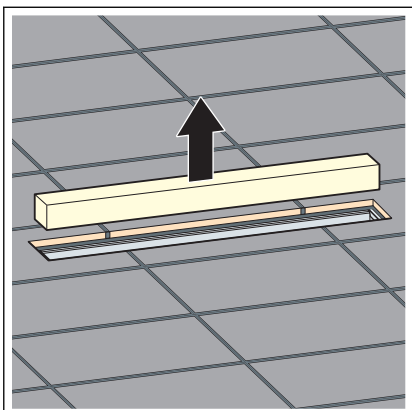

➤ Remove the site protection.

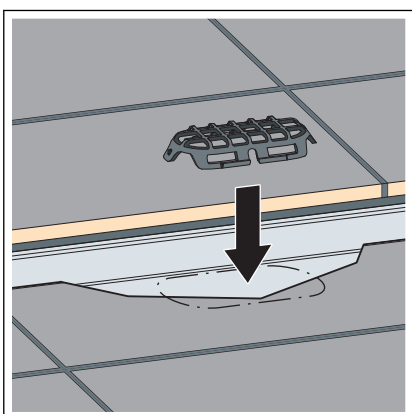

➤ Fit the sieve insert.

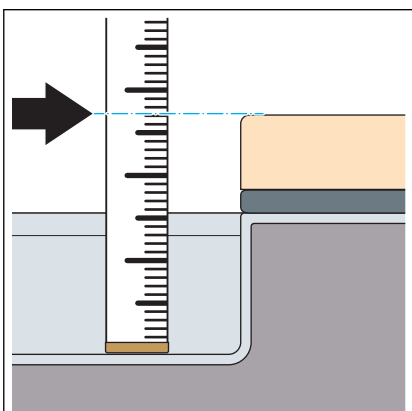

➤ Determine the height required from the shower channel base to the upper edge of the tiles.

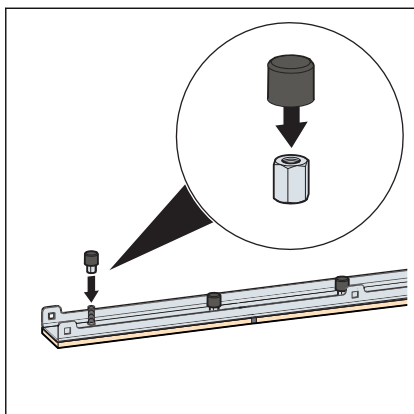

- Mount the rubber caps.
- Screw the spacer for the height adjustment of the grate onto the threaded pins.
With nut M5x8 from 6-10 mm.
With nut M5x12 from 8-15 mm.

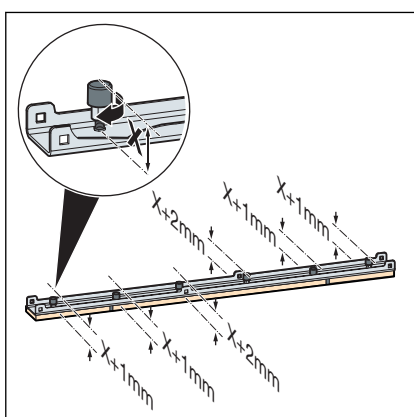

- Set the distance using the threaded feet.
For flooring heights from 6-15 mm.

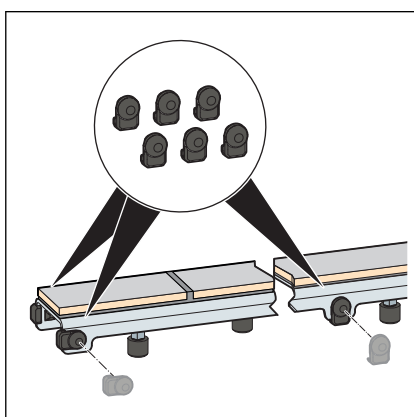

- Insert the plug.

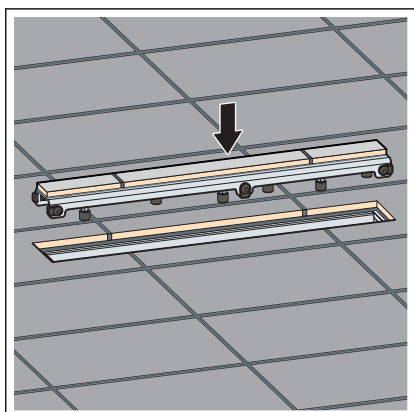

- Insert the grate and, if necessary, adjust slightly.
For flooring heights greater than 15 mm, use extension set (model 497.10).

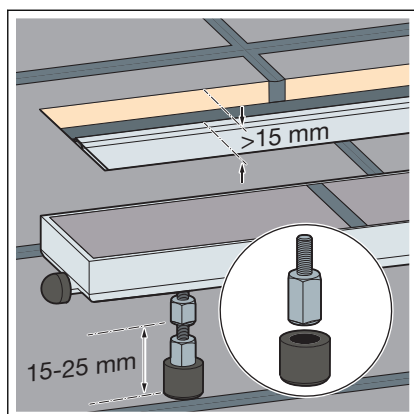

- Mount the additional threaded feet.

3.2.2 Care



NOTICE! Risk of damage due to unsuitable cleaning agent.

The following cleaning agents can damage chrome-plated surfaces and therefore may not be used:

- Scouring agent
- Abrasive sponges
- Lime, plaster or cement dissolver
- Solvents or other acidic cleaning agents

Normal soap or a mild cleaning agent can be used for regular care and prevention of lime scale. Under no circumstances should scouring agent or scratching objects be used.

Strong stains, even around the drain unit and the siphon, can be removed using typical household cleaner. Please note that the cleaning agent must be rinsed off thoroughly with clear water after the prescribed soaking time. There should be no residue on the components.

3.3 Disposal

Separate the product and packaging materials (e. g. paper, metal, plastic or non-ferrous metals) and dispose of in accordance with valid national legal requirements.



Viega Technology GmbH & Co. KG

service-technik@viega.de

viega.com

INT • 2020-08 • VPN170023

