

Instructions for Use

Geopress K Gas flow monitor type A/D



for shutting off the flow of gas when the gas flow volume exceeds a prescribed value due to an unintended release of gas

Model
9753.2

Year built (from)
06/2016

viega

Table of contents

1	About these instructions for use	3
	1.1 Target groups	3
	1.2 Labelling of notes	3
	1.3 About this translated version	4
2	Product information	5
	2.1 Standards and regulations	5
	2.2 Intended use	6
	2.2.1 Areas of application	6
	2.2.2 Media	6
	2.3 Product description	7
	2.3.1 Overview	7
	2.3.2 Gas flow monitor	8
	2.3.3 Markings on components	8
	2.3.4 Compatible connecting pieces for the tapping valve	8
	2.3.5 Operating mode	10
	2.3.6 Technical data	10
3	Handling	12
	3.1 Transport	12
	3.2 Storage	12
	3.3 Assembly information	12
	3.3.1 Mounting instructions	12
	3.3.2 Required tools	13
	3.4 Assembly	13
	3.4.1 Installing the sleeve with gas flow monitor	13
	3.4.2 Leakage test	15
	3.5 Disposal	15

1 About these instructions for use

Trade mark rights exist for this document; for further information, go to viega.com/legal.

1.1 Target groups

The information in this manual is directed at utility and pipeline construction companies and their technical professionals.

Only specialist companies which can prove they are qualified in accordance with the applicable directives may be engaged for the construction of gas and potable water house service connections, see ↗ *'Regulations from section: Target groups'* on page 5.

Individuals without the abovementioned training or qualification are not permitted to mount, install and, if required, maintain this product. This restriction does not extend to possible operating instructions.

The installation of Viega products must take place in accordance with the general rules of engineering and the Viega instructions for use.

1.2 Labelling of notes

Warning and advisory texts are set aside from the remainder of the text and are labelled with the relevant pictographs.



DANGER!

This symbol warns of possible life-threatening injury.



WARNING!

This symbol warns of possible serious injury.



CAUTION!

This symbol warns of possible injury.



NOTICE!

This symbol warns of possible damage to property.



This symbol gives additional information and hints.

1.3 About this translated version

This instruction for use contains important information about the choice of product or system, assembly and commissioning as well as intended use and, if required, maintenance measures. The information about the products, their properties and application technology are based on the current standards in Europe (e.g. EN) and/or in Germany (e.g. DIN/DVGW).

Some passages in the text may refer to technical codes in Europe/Germany. These should serve as recommendations in the absence of corresponding national regulations. The relevant national laws, standards, regulations, directives and other technical provisions take priority over the German/European directives specified in this manual: The information herein is not binding for other countries and regions; as said above, they should be understood as a recommendation.

2 Product information

2.1 Standards and regulations

The following standards and regulations apply to Germany / Europe and are provided as a support feature.

Regulations from section: Target groups

Scope / Notice	Regulations applicable in Germany
Qualification of specialist companies	DVGW-Arbeitsblatt GW 301

Regulations from section: Application areas

Scope / Notice	Regulations applicable in Germany
Planning, execution, modification and operation of gas house service connections	DVGW-Arbeitsblatt G 459-1
Planning, execution, modification and operation of gas house service connections	DVFG-Arbeitsblatt TRF 2021
Planning, execution, modification and operation of gas house service connections	DVGW-Arbeitsblatt G 472
Planning, execution, modification and operation of gas house service connections	DVGW-Arbeitsblatt G 469

Regulations from section: Media

Scope / Notice	Regulations applicable in Germany
Gas characteristics	DVGW-Arbeitsblatt G 260
Liquid gases in gaseous state	DVFG-Arbeitsblatt TRF

Regulations from section: Technical data

Scope / Notice	Regulations applicable in Germany
Basis for the technical inspection	DVGW G 5305-2 (P)

Regulations from section: Leakage test

Scope / Notice	Regulations applicable in Germany
Leakage test of gas household connection installations	DVGW-Arbeitsblatt G 459-1
Leakage test of gas household connection installations	DVGW-Arbeitsblatt G 469

2.2 Intended use



Agree the use of the model for areas of application and media other than those described with Viega.

2.2.1 Areas of application

The gas flow monitor is suitable for use in gas house service connections. As active protection, the gas flow monitor interrupts the gas supply of the house service connection in case of accident.

Gas installation

For planning, execution, modification and operation of gas house service connections, observe the applicable regulations, see ↗ *'Regulations from section: Application areas'* on page 5.

2.2.2 Media

The model is suitable for gases in accordance with applicable DVGW regulations, as well as liquefied gases, only in their gaseous state, in accordance with applicable DVFG regulations, see ↗ *'Regulations from section: Media'* on page 5

The max. operating pressure depends on the type of pipe used and the specific application.

Gas

- Operating pressure $p_{\max} = 1.0 \text{ MPa}$ (10 bar)
(with open gas flow monitor)

The maximum load of the closed gas flow monitor is 0.6 MPa (6 bar).

2.3 Product description

2.3.1 Overview

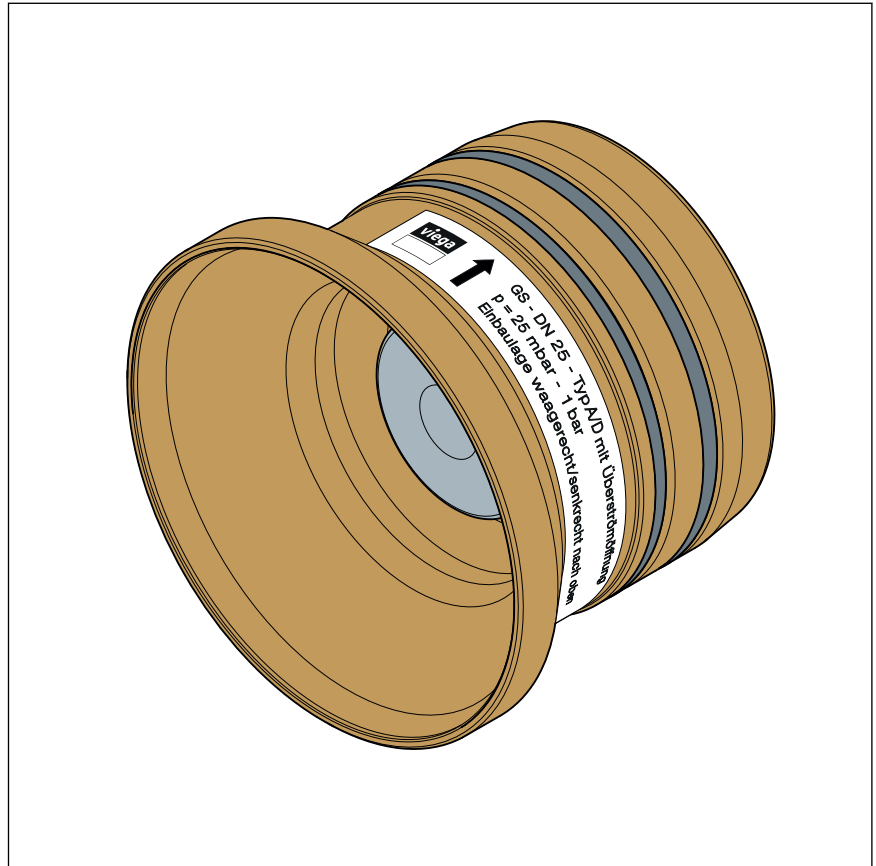

Fig. 1: 9753.2

The model is available in the following dimensions: d 32 / 40 / 50 / 63.

2.3.2 Gas flow monitor

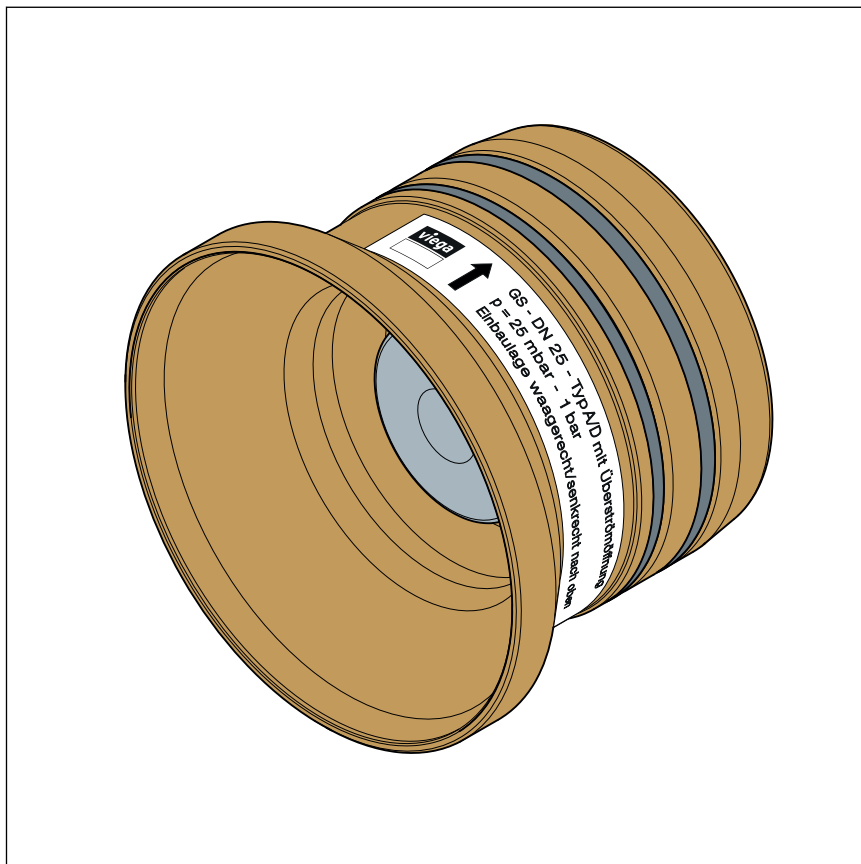
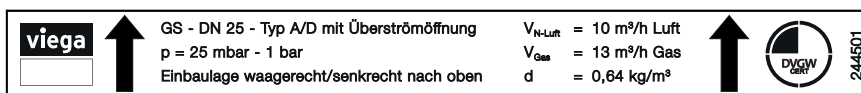

Fig. 2: 9753.2

The gas flow monitor is integrated into a sleeve made of gunmetal/silicon bronze. This is inserted into a connecting piece for the tapping valve and then mounted in the tapping valve along with the connecting piece.

2.3.3 Markings on components



A sticker with the specifications is applied to the gas flow monitor. The installation direction is shown by an arrow. The installation direction must be observed to ensure the functionality of the gas flow monitor.

2.3.4 Compatible connecting pieces for the tapping valve

The gas flow monitor can be used with the following connecting pieces for the tapping valve:

- Geopress K connecting pieces model 9793G, 9794G or 9794.1G
- Geopress G connecting pieces model 9693G, 9694G or 9694.1G

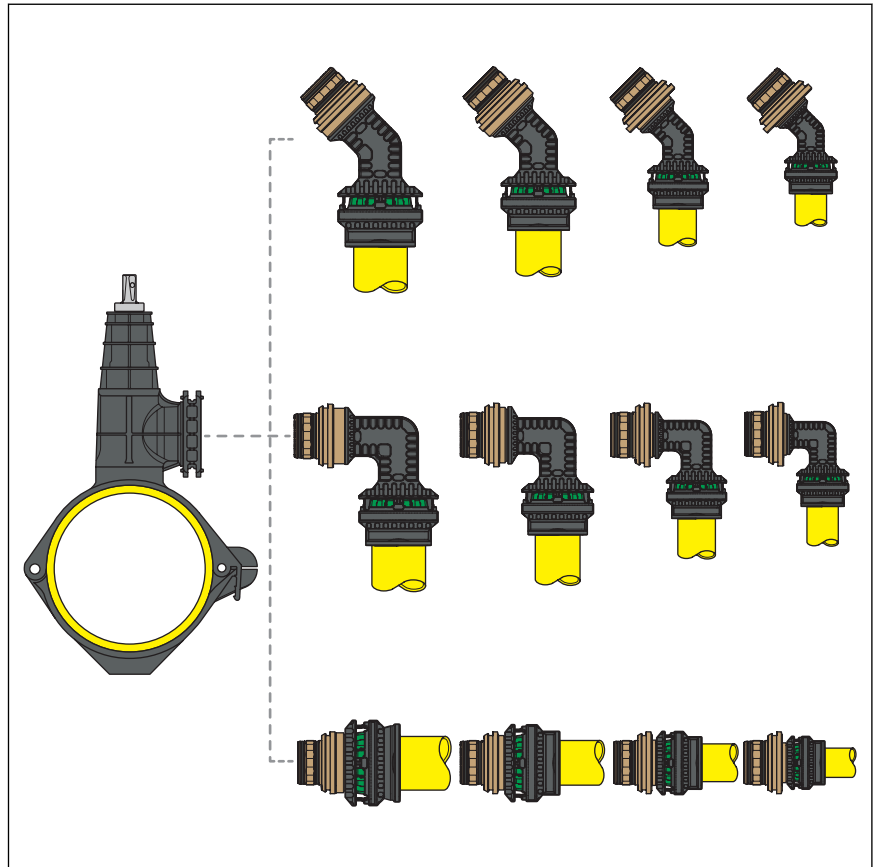

Fig. 3: Connecting pieces Geopress K

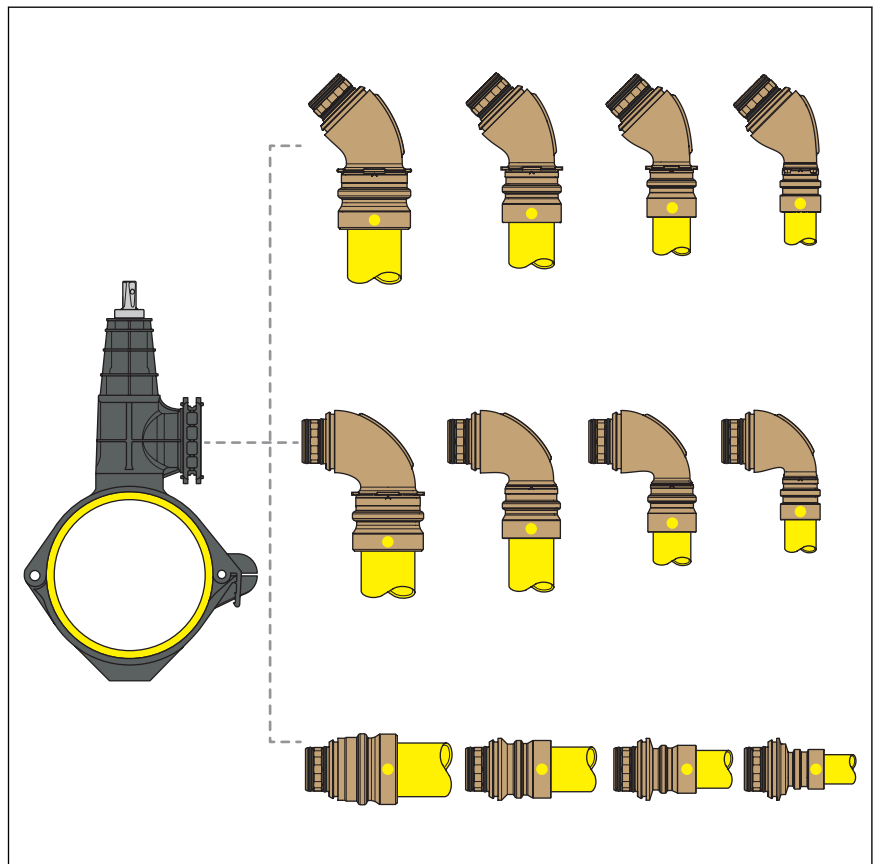

Fig. 4: Connecting pieces Geopress G



Maxiplex connecting pieces cannot be used.

2.3.5 Operating mode

Gas flow monitor (GFM)

Geopress K gas flow monitors are flow-activated fittings and serve as an active protective measure against the escape of gas in the case of a damaged gas house service connection.

- The gas flow monitor consists of a closing plate, which is held open during intended operation use by a spring force determined by type. The gas flow monitor therefore has a defined flow direction.
- In the case of a fault, the flow volume and the pressure behind the gas flow monitor change so that the spring force is no longer sufficient to hold the GFM open. The closing plate sits in its valve seat and closes the pipe. A further release of gas is prevented.
- The gas flow monitor is equipped with an overflow opening. It therefore opens automatically after a fault has been repaired. The opening process can be accelerated by the creation of counter pressure.

2.3.6 Technical data

Geopress K Gas flow monitors comply with the technical test regulation in accordance with the applicable regulations, see [Chapter 2.1 'Standards and regulations'](#) on page 5.

Operating pressure range GFM type A/D

Operating pressure range and building requirement	Place of installation	Construction size
0.0025–0.1 MPa (0.025–1 bar) DN related $\Delta p \leq 2.5 \text{ hPa}$ (2.5 mbar) Overflow volume \leq 30 dm ³ /h with 0.01 MPa (0.1 bar)	Directly at the tapping valve	up to DN 50 [d _a 63]

Flow and pressure loss values GFM type A/D

Nominal width [DN]	Nominal volume flow [m ³ /h air]	Nominal volume flow [m ³ /h gas]	Δp
25 [d _a 32]	10	13	2.00 hPa (2.00 mbar)
32 [d _a 40]	13	17	2.48 hPa (2.48 mbar)
40 [d _a 50]	19	25	2.50 hPa (2.50 mbar)
50 [d _a 63]	31	40	2.40 hPa (2.40 mbar)

In its delivery state, the gas flow monitor is preset for the operating pressure range of the respective type. On-site setting is not necessary.

Guide values for the protectable pipe length

Pipe length which can be protected when a gas flow monitor pursuant to the applicable regulations is used, see [Chapter 2.1 'Standards and regulations'](#) on page 5.

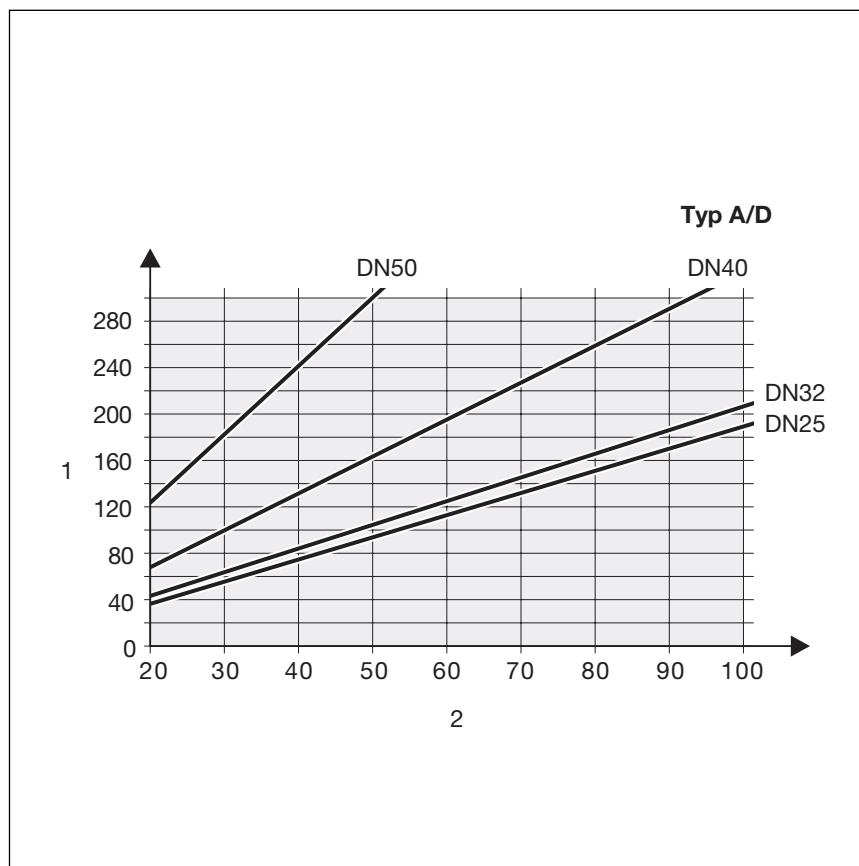

Fig. 5: Guide values for resistance coefficient $\zeta=10$ for the tapping valve and the main shut-off device

- 1 - Length (m)
- 2 - Mains system pressure (hPa)

3 Handling

3.1 Transport



Leave the gas flow monitor in the original packaging until use so that sensitive components do not become contaminated.

3.2 Storage



Leave the gas flow monitor in the original packaging until use so that sensitive components do not become contaminated.

3.3 Assembly information

3.3.1 Mounting instructions

Geopress K gas flow monitor:

- Install in the immediate vicinity of the tapping valve.
- Installation position horizontally or vertically upwards
- Check that the gas flow monitor is suitably designed for the application before installing.
- Observe installation direction.
- Excessive use of lubricants can impair the function.

Check scope of delivery

The following components must be included:

- Gas flow monitor with protective cap
- Sticker "Specifications"
- Information sign "Main shut-off device"
- Cable tie

3.3.2 Required tools

Install the gas flow monitor into the connecting piece for the tapping valve by hand without tools. The following tools are required to manufacture the press connection of the press connector:

- pipe cutter, pipe shear or saw
- deburrer and coloured pen for marking
- Battery-powered press machine
- hinged adapter jaw model 2296.2
 - Z2 with 32–63 mm diameter
- Press ring model 9796.1



Viega recommends the use of Viega system tools when installing the press fittings.

The Viega system press tools have been developed and tailored specifically for the installation of Viega press connector systems.

For information on how to combine Viega press machines with systems and accessories, please visit *Viega Tool Assistant*.

3.4 Assembly

3.4.1 Installing the sleeve with gas flow monitor

Preconditions:

- The gas flow monitor is suitably configured for the project.
- Push the sleeve into the selected connecting piece of the tapping valve as far as it will go.

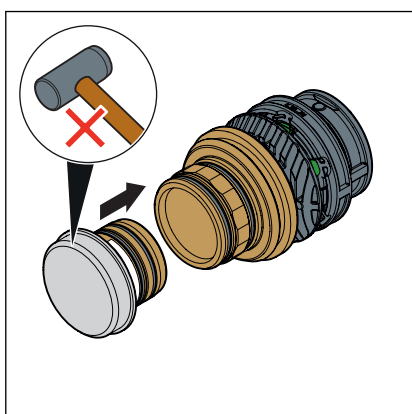

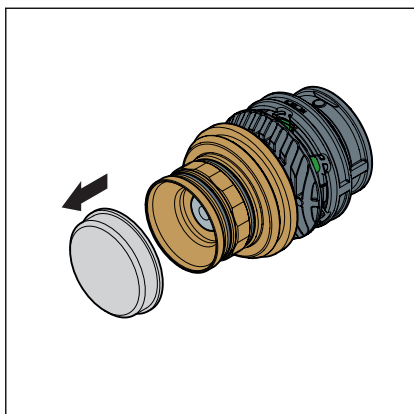

► Wait until you are ready for further processing before manually removing the protective cap of the gas flow monitor.

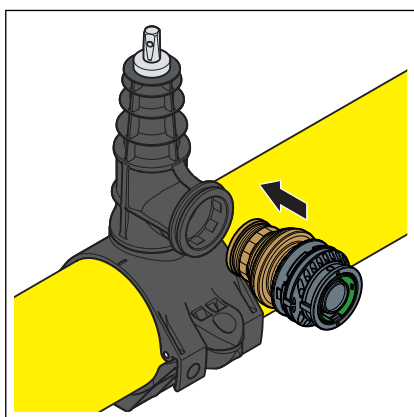

► Mount the connecting piece to the tapping valve.

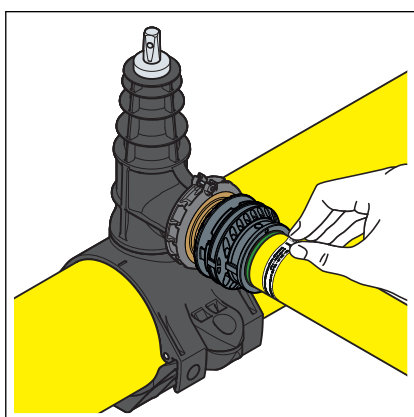

► Attach the notice label to the pipe of the installed gas flow monitor.

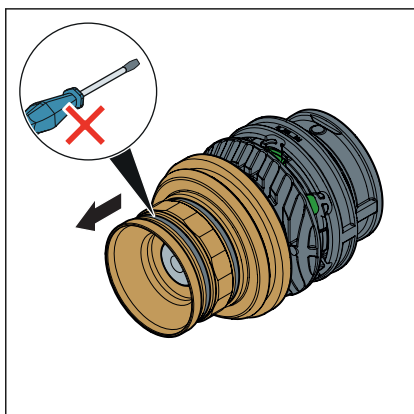

INFO! No tools are required for disassembly. Do not use tools.

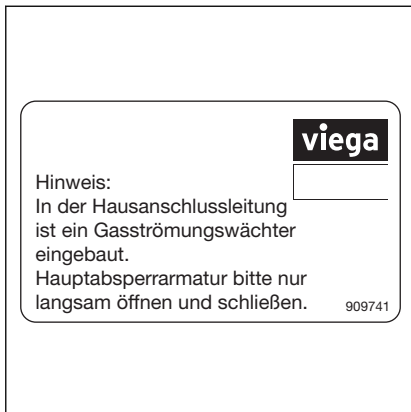

- Attach the information sign "Main shut-off device" to the MSD.

3.4.2 Leakage test

Perform a leakage test according to the applicable regulations before commissioning the connection line, see [↗ 'Regulations from section: Leakage test' on page 6.](#)

Carry out the test on a house service connection that is finished but not yet covered. The result of the leakage test must be documented as proof of the safety of the pipeline.



- The testing air must flow in slowly upstream to the gas flow monitor so that it does not close.
- Testing opened gas flow monitors with air is permitted up to a maximum pressure of 1.0 MPa (10 bar).
- The closed gas flow monitor may only be subjected to pressures of a maximum of 0.6 MPa (6 bar).

3.5 Disposal

Separate the product and packaging materials (e. g. paper, metal, plastic or non-ferrous metals) and dispose of in accordance with valid national legal requirements.



Viega GmbH & Co. KG
service-technik@viega.de
viega.com

INT • 2021-11 • VPN210425

