

Instructions for Use

Geopress K gas adapter with SC-Contur

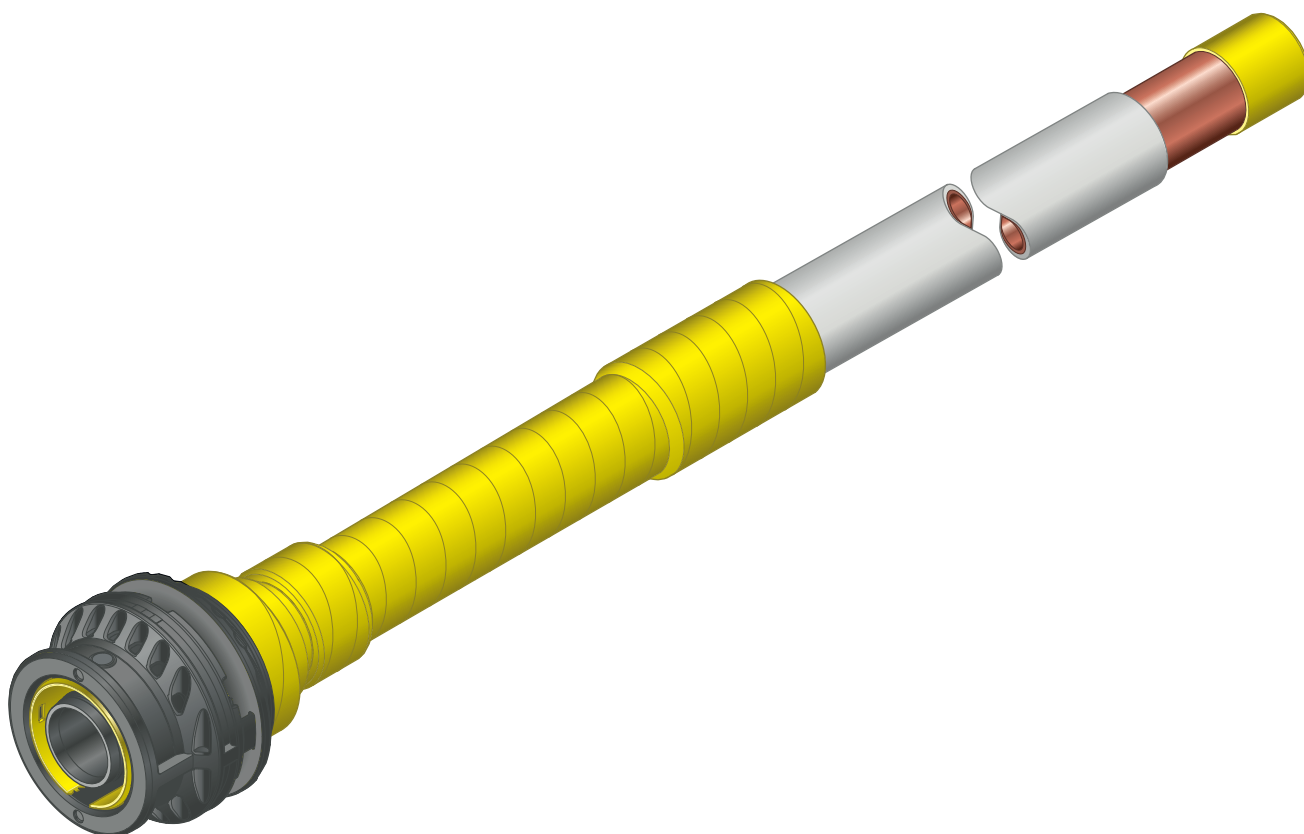

for natural-gas plants, liquid-gas plants, PE8 pipe to copper pipe

Model
9713.1G

viega

Table of contents

1	About these instructions for use	3
	1.1 Target groups	3
	1.2 Labelling of notes	3
	1.3 About this translated version	4
2	Product information	5
	2.1 Standards and regulations	5
	2.2 Intended use	7
	2.2.1 Areas of application	7
	2.2.2 Media	7
	2.3 Product description	8
	2.3.1 Overview	8
	2.3.2 Pipes	8
	2.3.3 Connections	9
	2.3.4 Markings on components	9
	2.4 Information for use	10
	2.4.1 Corrosion	10
3	Handling	11
	3.1 Transport	11
	3.2 Storage	11
	3.3 Assembly information	11
	3.3.1 Mounting instructions	11
	3.3.2 Space requirements and intervals	12
	3.3.3 Required tools	13
	3.4 Assembly	13
	3.4.1 Cutting pipes to length	13
	3.4.2 Deburring the pipes	14
	3.4.3 Pressing the connection	15
	3.4.4 Leakage test	17
	3.5 Disposal	17

1 About these instructions for use

Trade mark rights exist for this document; for further information, go to viega.com/legal.

1.1 Target groups

The information in this manual is directed at utility and pipeline construction companies and their technical professionals.

Only specialist companies which can prove they are qualified in accordance with the applicable directives may be engaged for the construction of gas house service connections, see ↗ *'Regulations from section: Target group'* on page 5.

The installation of Viega products must take place in accordance with the general rules of engineering and the Viega instructions for use.

1.2 Labelling of notes

Warning and advisory texts are set aside from the remainder of the text and are labelled with the relevant pictographs.



DANGER!

This symbol warns of possible life-threatening injury.



WARNING!

This symbol warns of possible serious injury.



CAUTION!

This symbol warns of possible injury.



NOTICE!

This symbol warns of possible damage to property.



This symbol gives additional information and hints.

1.3 About this translated version

This instruction for use contains important information about the choice of product or system, assembly and commissioning as well as intended use and, if required, maintenance measures. The information about the products, their properties and application technology are based on the current standards in Europe (e.g. EN) and/or in Germany (e.g. DIN/DVGW).

Some passages in the text may refer to technical codes in Europe/Germany. These should serve as recommendations in the absence of corresponding national regulations. The relevant national laws, standards, regulations, directives and other technical provisions take priority over the German/European directives specified in this manual: The information herein is not binding for other countries and regions; as said above, they should be understood as a recommendation.

2 Product information

2.1 Standards and regulations

The following standards and regulations apply to Germany / Europe and are provided as a support feature.

Regulations from section: Target group

Scope / Notice	Regulations applicable in Germany
Qualification of specialist companies	DVGW-Arbeitsblatt GW 301

Regulations from section: Application areas

Scope / Notice	Regulations applicable in Germany
Application in gas installations	DVGW G 260
Planning, execution, modification and operation of gas house service connections	DVGW-Arbeitsblatt G 459-1
Planning, execution, modification and operation of liquid gas installations	DVFG-TRF 2021
Gas supply lines made of plastic pipes up to 1.6 MPa (16 bar) – installation.	DVGW-Arbeitsblatt G 472
Gas transportation / gas distribution pressure testing procedures	DVGW-Arbeitsblatt G 469

Regulations from section: Media

Scope / Notice	Regulations applicable in Germany
Gas, hydrogen and liquid gas in the gaseous state	DVGW-Arbeitsblatt G 260

Regulations from section: Pipes

Scope / Notice	Regulations applicable in Germany
Permitted types of pipes (PE) – gas supply	DVGW-Arbeitsblatt GW 335-A2
Permitted types of pipes (PE) – gas supply	DIN EN 1555
Permitted types of pipes (PE-X) – gas supply	DVGW-Arbeitsblatt GW 335-A3
Seamless round copper pipes for water and gas supply lines for sanitary and heating installations.	DIN EN 1057
Completion of moulded pieces for soldered fittings in underground external lines	DIN EN 1254-1
Completion of moulded pieces for soldered connections in gas and potable-water installations	DVGW-Arbeitsblatt GW 6
Copper capillary solder fittings for gas and potable-water installations	DVGW-Arbeitsblatt GW 8
Approval of press connectors for use with copper pipes	DVGW G 5614

Regulations from section: Corrosion

Scope / Notice	Regulations applicable in Germany
(Subsequent) corrosion protection for underground installation	DIN 30672

Regulations from section: Transport

Scope / Notice	Regulations applicable in Germany
Transport	Einbauhinweise KRV A 1465 - Pressure pipelines

Regulations from section: Storage

Scope / Notice	Regulations applicable in Germany
Requirements for material storage	Einbauhinweise KRV A 1465 - Pressure pipelines

Regulations from section: Notes on mounting

Scope / Notice	Regulations applicable in Germany
Threshold values for ovalities	DIN EN 1555-2, Table 1

Regulations from section: Leakage test

Scope / Notice	Regulations applicable in Germany
Leakage test before commissioning the connection line	DVGW-Arbeitsblatt G 459-1
Leakage test before commissioning the connection line	DVGW-Arbeitsblatt G 469

2.2 Intended use



Agree the use of the model for areas of application and media other than those described with Viega.

The system can be applied at outdoor temperatures from -10 °C to 50 °C. The component temperatures of the press connectors and the press machine must not be less than -5 °C.

2.2.1 Areas of application

The system is intended for use in natural-gas and liquid-gas supply.

For planning, execution, modification and operation of gas house service connections, observe the applicable regulations, see [☞ 'Regulations from section: Application areas' on page 5.](#)

2.2.2 Media

The system is suitable for the following media, see [☞ 'Regulations from section: Media' on page 5:](#)

- Natural gas
- Liquid gas in the gaseous phase
- Hydrogen mixtures

The max. operating pressure and the max. operating temperature depend on the type of pipe used and the specific application.

- Operating pressure $p_{\max} = 1.0 \text{ MPa}$ (10 bar)

2.3 Product description

2.3.1 Overview

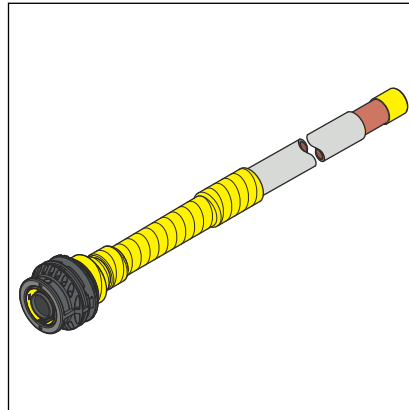

The adapter is suitable for use in liquid gas systems, especially for the connection of liquid gas tanks. The press connection is hard soldered with a copper pipe (22x1 mm) for underground external pipelines.

In this way, press connection technology can be used continuously for the connection of a liquid gas tank in both overground and underground external pipeline applications.

The model is available in the following dimension:

d1	d2
32	22

2.3.2 Pipes

Only the following plastic pipes may be used for installations with Geopress K gas adapters:

Permitted types of PE pipes – gas supply

Type of pipe ¹⁾	Pipe series SDR	MOP
PE 80	11.0	0.4 MPa (4 bar)
PE 100	11.0	1.0 MPa (10 bar)
PE-X	11.0	0.8 MPa (8 bar)

¹⁾ see ↗ 'Regulations from section: Pipes' on page 6

Soldered copper pipe

For further processing of the soldered-in copper pipe, press connections such as described in the standard can be used in case of overground external pipelines (↗ 'Regulations from section: Pipes' on page 6).

Press connectors from the Profipress G system are suitable, for example.

In the case of underground external pipelines, the soldered connection must be made as a hard solder connection using the proper equipment. For this purpose, use moulded parts in compliance with the standards, see ↗ *'Regulations from section: Pipes'* on page 6.



Handmade moulded pieces (e.g. sleeves, T-pieces etc.) are not permitted.

2.3.3 Connections

Press connection

The press connectors have a support sleeve with a 5-tooth sealing contour on it. Part of this sealing contour is a circumferential bead in which an HNBR sealing element is inserted. During pressing, the pipe is pressed onto the sealing contour and sealed from the inside so that the press connector is permanently attached to the pipe. Geopress K press connectors are equipped with a yellow fibreglass-reinforced clamping ring made of POM for a longitudinal-force-resistant connection. The press connectors have a window for checking the insertion depth.

The threads of Geopress K gas adapters are made of metal and produced in accordance with applicable guidelines. Plug-in pieces and connecting pieces for the tapping valve also have metal components.

2.3.4 Markings on components

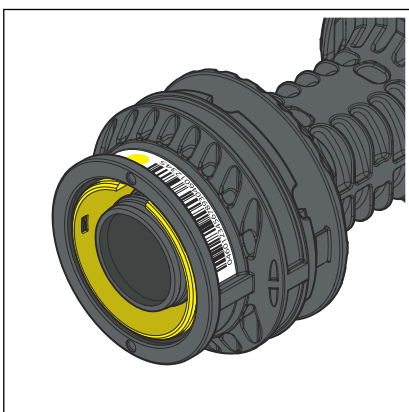

Fig. 1: Marking

The coloured dot shows that the press connector is equipped with the SC-Contur.

If there is a yellow dot, the press connector is suitable for gas.

The traceability code on the press connector allows every press connector to be traced back and simplifies the documentation in as-completed drawings.

2.4 Information for use

2.4.1 Corrosion

Due to a lower probability of corrosion in the case of laying in the ground and in contact with ground and surface waters with pH-values between 6 and 8, corrosion protection is not required in the case of press connectors with metal components. Soils containing ammoniac require corrosion protection in acc. with the pertinent guidelines, see ↪ *'Regulations from section: Corrosion' on page 6.*

Only components and supplies (e. g. sealant) that have been awarded a DVGW test symbol may be used.

3 Handling

3.1 Transport



Do not remove the adapters from the packaging until immediately before use.

Leave the protective caps in the press connector until you are ready to use it.

For transport, comply with the requirements specified in the applicable regulations, see ↗ *'Regulations from section: Transport' on page 6*

3.2 Storage

For storage, comply with the requirements specified in the applicable regulations, see ↗ *'Regulations from section: Storage' on page 6:*

- Avoid strong sunlight and heating.
- In addition, observe the instructions provided by the pipe manufacturer.

3.3 Assembly information

3.3.1 Mounting instructions

Checking system components

System components may, in some cases, have become damaged through transportation and storage.

- Check all parts.
- Replace damaged components.
- Do not repair damaged components.

Inspect pipes visually for the following damage before installation:

- Ovalities: threshold values must not be exceeded, see ↗ *'Regulations from section: Notes on mounting' on page 7.*
- Dents
- Cracks
- Grooves on the exterior
- Scoring inside the pipe (not permissible)
- damaged pipe ends

Only install the sections of the pipes, which do not exhibit these features.

3.3.2 Space requirements and intervals

Minimum distance to the pre-fabricated solder seam



NOTICE!
Strong heating can damage the solder joint

Heating the pipe too close to the Geopress K gas press end may damage a solder joint there.

- Do not go below the specified minimum installation length when using the brazing technique.

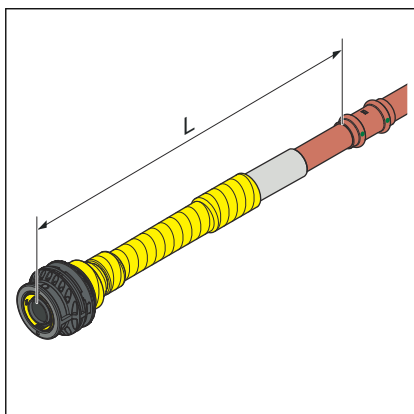

Minimum distance L [mm] to the pre-fabricated solder seam

Hard solder technology	Press connecting technology
350	200

Interval between the pressings



NOTICE!
Leaking press connections due to pipes being too short!

If two press connectors are to be mounted onto a pipe at a short distance apart, the pipe must not be too short. If the pipe is not inserted up to the prescribed insertion depth in the press connector during pressing, the connection may become leaky.

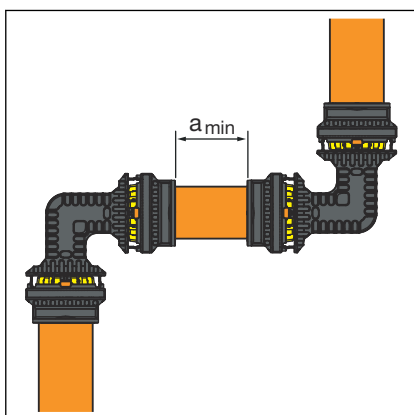

Minimum distance with press rings d32

d	a _{min} [mm]
32	20

Z dimensions

For the Z dimensions, refer to the respective product page in the online catalogue.

3.3.3 Required tools

The following tools are required for production of a press connection:

- Pipe cutter, pipe shear or saw
- Deburrer and coloured pen for marking
- Battery-powered press machine
- Hinged adapter jaw model 2296.2
 - Z2 with 32–63 mm diameter
- Press ring model 9796.1



Viega recommends the use of Viega system tools when installing the press fittings.

The Viega system press tools have been developed and tailored specifically for the installation of Viega press connector systems.

3.4 Assembly

3.4.1 Cutting pipes to length

For information about tools, also see [↗ Chapter 3.3.3 'Required tools'](#) on page 13.

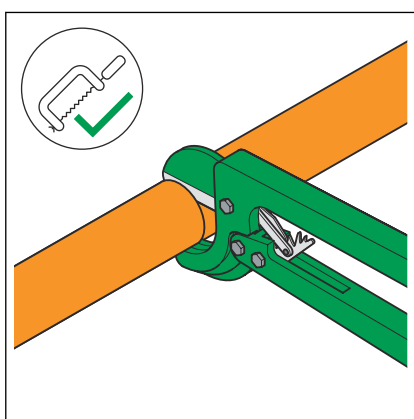
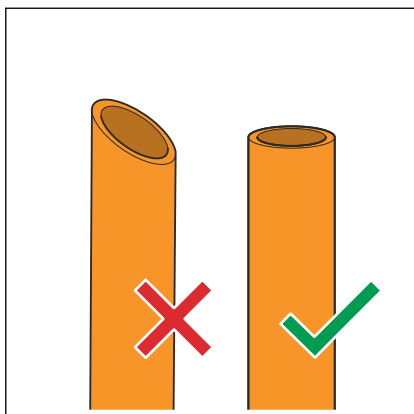

- ▶ Cut the pipe to length at a right angle as accurately as possible using pipe shears, a pipe cutter or a saw to ensure correct and even pipe insertion depth.

3.4.2 Deburring the pipes

If a burr appears when the pipes are cut, then the pipe ends must be carefully deburred on the inside and outside.

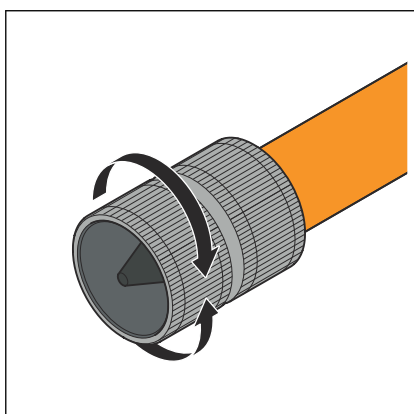

- ▶ Deburr the inside and outside of the pipe.

3.4.3 Pressing the connection

Requirements:

- The pipe end is not bent or damaged.
- The pipe is deburred.
- Check the internal and external pipe surfaces for contamination, and clean them as required.
Remove any shavings.

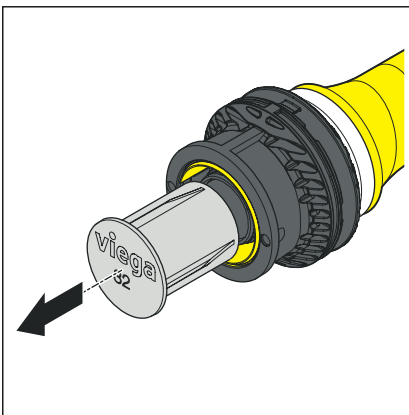
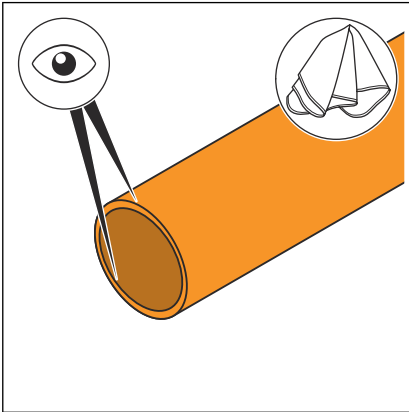

- Remove the protective cap immediately before fitting the pipe and protect the connection against dirt ingress.

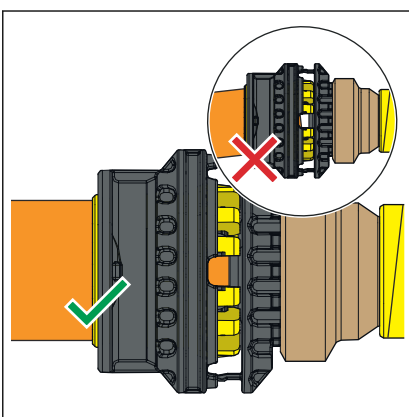

- To avoid damaging the sealing element, push the press connector straight onto the pipe without twisting.

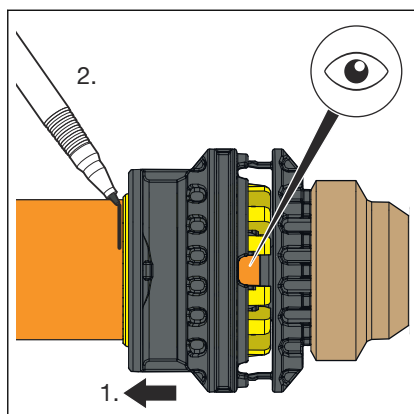

- Check the insertion depth in the inspection window and mark it.

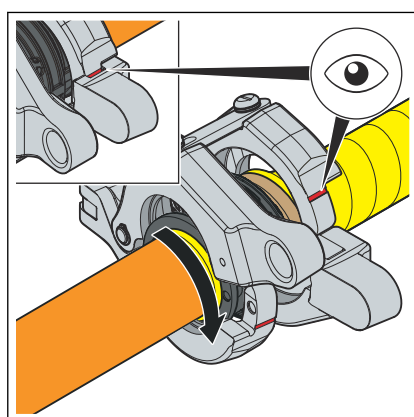

- Open the press ring and check for dirt and function.
 - Place the press ring around the press connector.
- Observe the press connector side and pipe side of the press ring.
The press ring is properly closed when the red marking can no longer be seen.

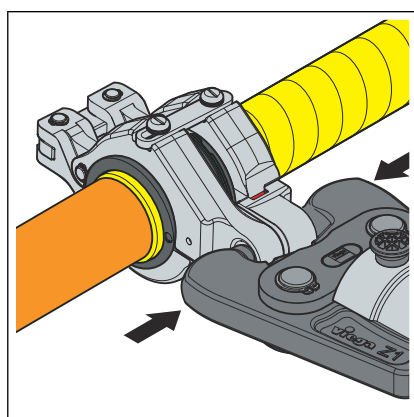

- Carry out the pressing.

NOTICE!

The press ring must close completely during pressing.

- Make sure there is adequate space at the pressing point.
- Keep the press contour and the area around the pressing point clean.

□ The clamping ring is easily recognised after successful pressing.

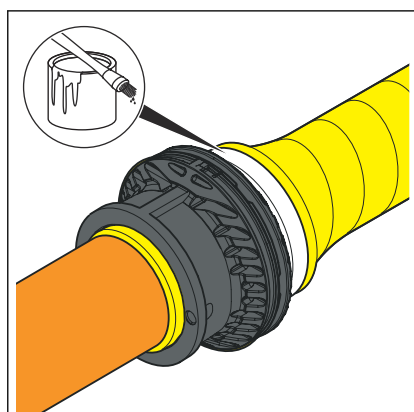

- Prime the press connector up to the centre with suitable primer.
- Allow the primer to flash off (observe manufacturer's instructions).

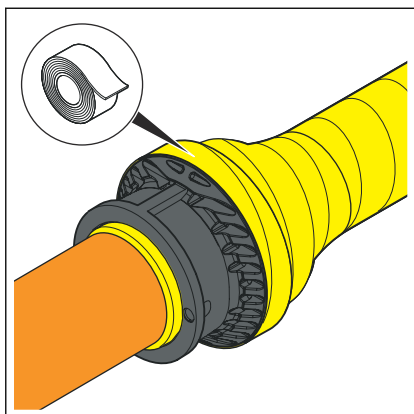

- Wrap the press connector up to the centre with corrosion protection bands that are designed to be applied cold (follow manufacturer's instructions).

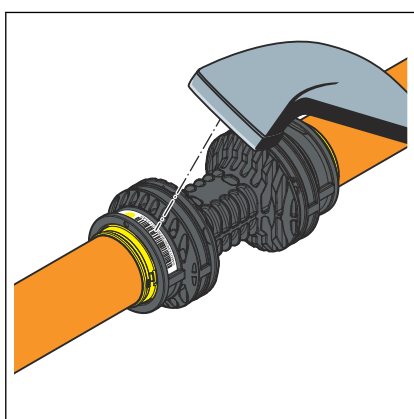

- Scan in the traceability code.

3.4.4 Leakage test



The leakage test can be carried out directly after the last pressing.

Perform a leakage test according to the applicable regulations before commissioning the connection line, see ↗ *'Regulations from section: Leakage test'* on page 7.

Carry out the test on a pipeline that is finished but not yet covered. The result of the leakage test must be documented as proof of the safety of the pipeline.

3.5 Disposal

Separate the product and packaging materials (e. g. paper, metal, plastic or non-ferrous metals) and dispose of in accordance with valid national legal requirements.



Viega GmbH & Co. KG
service-technik@viega.de
viega.com

INT • 2024-07 • VPN240073

