

Instructions for Use

Geopress K repair coupling with SC-Contur

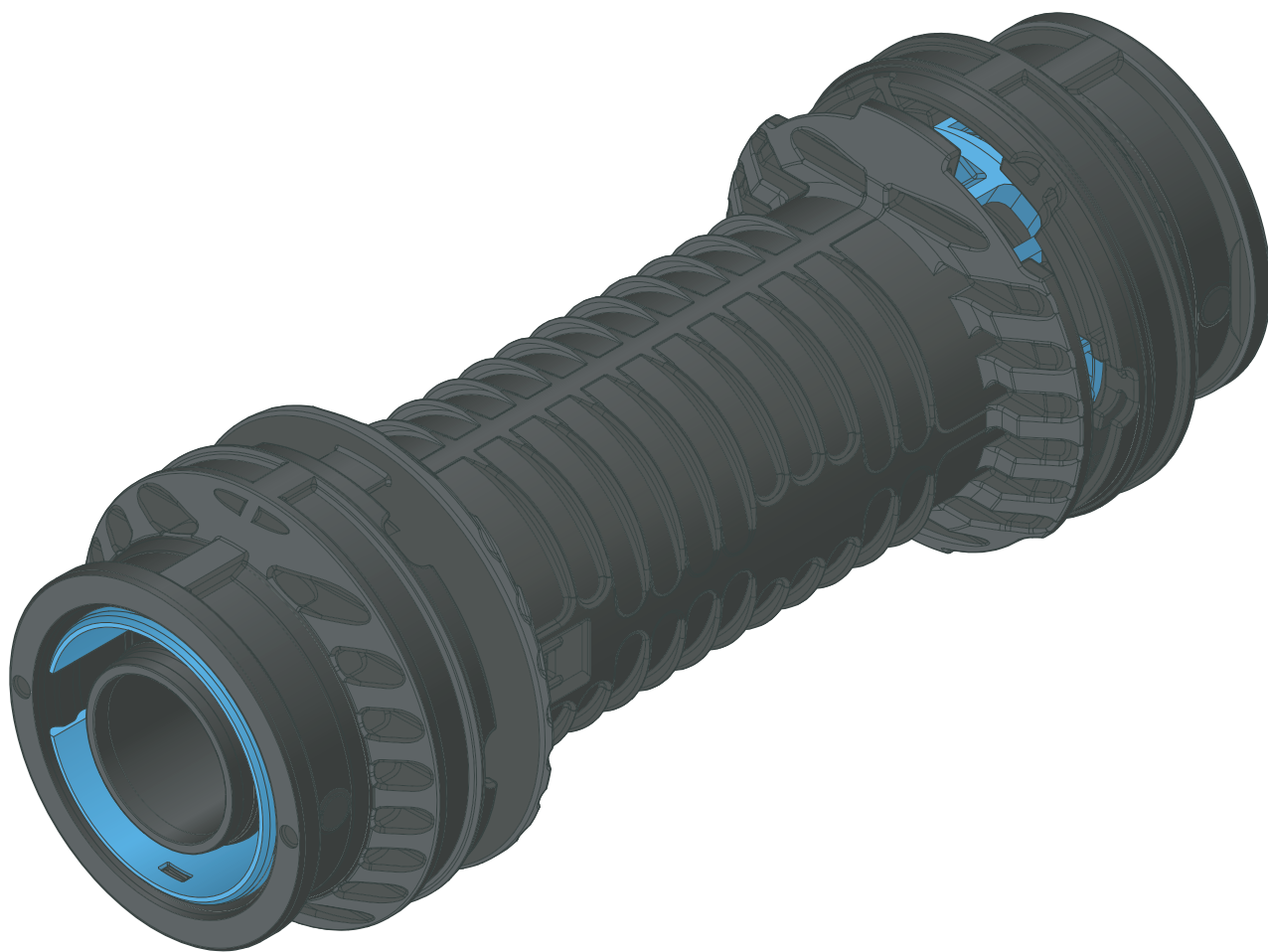

Model
9715.5TW

viega

Table of contents

1	About these instructions for use	3
	1.1 Target groups	3
	1.2 Labelling of notes	3
	1.3 About this translated version	4
2	Product information	5
	2.1 Standards and regulations	5
	2.2 Intended use	7
	2.2.1 Areas of application	7
	2.2.2 Media	7
	2.3 Product description	7
	2.3.1 Overview	7
	2.3.2 Pipes	8
	2.3.3 Press connectors	8
	2.3.4 Sealing elements	9
	2.3.5 Markings on components	9
3	Handling	10
	3.1 Transport	10
	3.2 Storage	10
	3.3 Assembly information	10
	3.3.1 Mounting instructions	10
	3.3.2 Space requirements and intervals	12
	3.3.3 Required tools	14
	3.4 Assembly	14
	3.4.1 Cutting pipes to length	14
	3.4.2 Deburring the pipes	15
	3.4.3 Pressing the connection	16
	3.4.4 Leakage test	20
	3.5 Disposal	20

1 About these instructions for use

Trade mark rights exist for this document; for further information, go to viega.com/legal.

1.1 Target groups

The information in this manual is directed at utility and pipeline construction companies and their technical professionals.

Only specialist companies which can prove they are qualified in accordance with the applicable directives may be engaged for the construction of potable water house service connections, see  'Regulations from section: Target group' on page 5.

The installation of Viega products must take place in accordance with the general rules of engineering and the Viega instructions for use.

1.2 Labelling of notes

Warning and advisory texts are set aside from the remainder of the text and are labelled with the relevant pictographs.



DANGER!

This symbol warns of possible life-threatening injury.



WARNING!

This symbol warns of possible serious injury.



CAUTION!

This symbol warns of possible injury.



NOTICE!

This symbol warns of possible damage to property.



This symbol gives additional information and hints.

1.3 About this translated version

This instruction for use contains important information about the choice of product or system, assembly and commissioning as well as intended use and, if required, maintenance measures. The information about the products, their properties and application technology are based on the current standards in Europe (e.g. EN) and/or in Germany (e.g. DIN/DVGW).

Some passages in the text may refer to technical codes in Europe/Germany. These should serve as recommendations in the absence of corresponding national regulations. The relevant national laws, standards, regulations, directives and other technical provisions take priority over the German/European directives specified in this manual: The information herein is not binding for other countries and regions; as said above, they should be understood as a recommendation.

2 Product information

2.1 Standards and regulations

The following standards and regulations apply to Germany / Europe and are provided as a support feature.

Regulations from section: Target group

Scope / Notice	Regulations applicable in Germany
Qualification of specialist companies	DVGW-Arbeitsblatt GW 301
Qualification and requirements in the potable water supplier	DVGW-Arbeitsblatt W 1000

Regulations from section: Application areas

Scope / Notice	Regulations applicable in Germany
Planning, execution, operation and maintenance of potable water house service connections	DIN EN 805
Planning, execution, operation and maintenance of potable water house service connections	DVGW-Arbeitsblatt W 400-1
Planning, execution, operation and maintenance of potable water house service connections	DVGW-Arbeitsblatt W 400-2
Planning, execution, operation and maintenance of potable water house service connections	DVGW-Arbeitsblatt W 400-3

Regulations from section: Media

Scope / Notice	Regulations applicable in Germany
Suitability for potable water	Trinkwasserverordnung (TrinkwV)

Regulations from section: Pipes

Scope / Notice	Regulations applicable in Germany
Permitted types of pipes (PE) – potable water supply	DIN EN 12201
Permitted use with piping materials in potable-water installations (PE-HD)	DIN 8074/75
Permitted types of pipes (PE) – potable water supply	DVGW-Arbeitsblatt GW 335-A2
Permitted types of pipes (PE-X) – potable water supply	DIN 16892/16893
Types of pipes (PE-X) – potable water supply	DVGW-Arbeitsblatt GW 335-A3

Regulations from section: Corrosion

Scope / Notice	Regulations applicable in Germany
(Subsequent) corrosion protection for underground installation	DIN 30672

Regulations from section: Storage

Scope / Notice	Regulations applicable in Germany
Requirements for material storage	DIN EN 806-4, Chapter 4.2

Regulations from section: Notes on mounting

Scope / Notice	Regulations applicable in Germany
Threshold values for ovalities	DIN EN 12201-2, Table 1

Regulations from section: Leakage test

Scope / Notice	Regulations applicable in Germany
Leakage test before commissioning the connection line	DVGW-Arbeitsblatt W 400-2
Leakage test before commissioning the connection line	DIN EN 805

2.2 Intended use



Agree the use of the model for areas of application and media other than those described with Viega.

The system can be applied at outdoor temperatures from -10 °C to 50 °C. The component temperatures of the press connectors and the press machine must not be less than -5 °C.

2.2.1 Areas of application

The system is intended for use in potable-water supply as well as in geothermal energy and cold local heating.

For planning, execution and operation of potable water house service connections, observe the applicable regulations, see ↗ 'Regulations from section: Application areas' on page 5.

2.2.2 Media

The system is suitable for the following media, see ↗ 'Regulations from section: Media' on page 5:

- Potable water
- Geothermal energy / cold local heating

The max. operating pressure and the max. operating temperature depend on the type of pipe used and the specific application.

- Operating temperature $T_{\max} = 25 \text{ °C}$
- Operating pressure $p_{\max} = 1.6 \text{ MPa (16 bar)}$

2.3 Product description

2.3.1 Overview



The model is available in the following dimensions: d32 / 40 / 50 / 63

2.3.2 Pipes

Only the following plastic pipes may be used for installations with Geopress K components:

Permitted types of pipes – potable water supply

Type of pipe ¹⁾	Pipe series SDR	MDP
PE 80	11.0	1.25 MPa (12.5 bar)
PE 100	11.0	1.6 MPa (16 bar)
PE-X	11.0	1.25 MPa (12.5 bar)

¹⁾ see  'Regulations from section: Pipes' on page 6

2.3.3 Press connectors



Fig. 1: Repair coupling

The press connectors have a support sleeve with a 5-tooth sealing contour on it. Part of this sealing contour is a circumferential bead in which a EPDM sealing element is inserted. During pressing, the pipe is pressed onto the sealing contour and sealed from the inside so that the press connector is permanently attached to the pipe. On the repair side, the repair coupling has an end-to-end support sleeve. The support sleeve is equipped with a specifically shaped clamping ring to allow it to be pushed onto the pipe. The press connectors have a window for checking the insertion depth.

SC-Contur

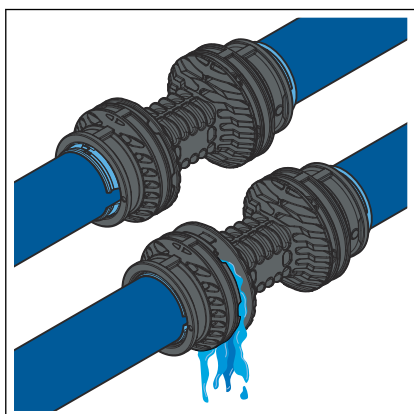

Fig. 2: SC-Contur

Viega press connectors are equipped with the SC-Contur. SC-Contur is a safety mechanism certified by the DVGW and ensures that the press connector leaks in an unpressed state. In this way, inadvertently unpressed connections are noticed during a leakage test.

Viega guarantees that accidentally unpressed connections become visible during a leakage test:

- with the wet leakage test in the pressure range from 0.1–0.65 MPa (1.0–6.5 bar)
- with dry leakage test in the pressure range from 22 hPa–0.3 MPa (22 mbar–3.0 bar)

2.3.4 Sealing elements

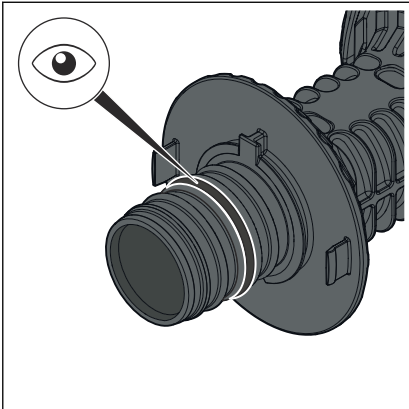

Fig. 3: EPDM sealing element

The press connectors are factory-fitted with EPDM sealing elements.

Area of use of the EPDM sealing element

Area of application	Potable water	Geothermal energy / cold local heating
Operating temperature [$T_{max.}$]	25 °C	50 °C
Operating pressure [$P_{max.}$]	1.6 MPa (16 bar)	0.6 MPa (6 bar)
Comments	—	—

2.3.5 Markings on components

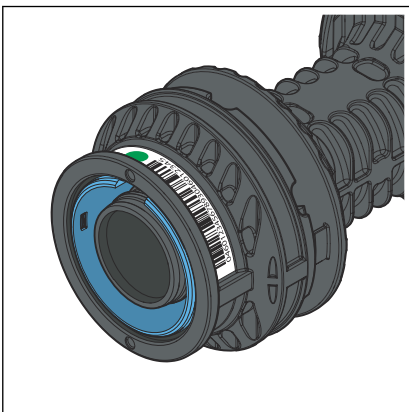

Fig. 4: Marking

The coloured dot shows that the press connector is equipped with the SC-Contur.

The traceability code on the press connector allows every press connector to be traced back and simplifies the documentation in as-completed drawings.

3 Handling

3.1 Transport



Do not remove the press connector from the packaging until immediately before use.

Leave the protective caps in the press connector until you are ready to use it.

3.2 Storage



Do not remove the press connector from the packaging until immediately before use.

3.3 Assembly information

3.3.1 Mounting instructions

Checking system components

System components may, in some cases, have become damaged through transportation and storage.

- Check all parts.
- Replace damaged components.
- Do not repair damaged components.

Inspect pipes visually for the following damage before installation:

- Ovalities: threshold values must not be exceeded, see  'Regulations from section: Notes on mounting' on page 6.
- Dents
- Cracks
- Grooves on the exterior
- Scoring inside the pipe (not permissible)
- damaged pipe ends

Only install the sections of the pipes, which do not exhibit these features.

Fitting the clamping ring and slip coupling

If the press connector is dirty, the slip coupling and clamping ring can be removed for cleaning. The position of the clamping ring and the slip coupling on the press connector must be observed when mounting.

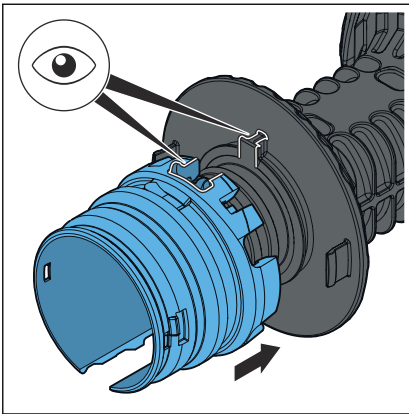

► Engage the clamping ring as shown.

NOTICE! Make sure that the sealing element is not damaged when fitting the clamping ring.

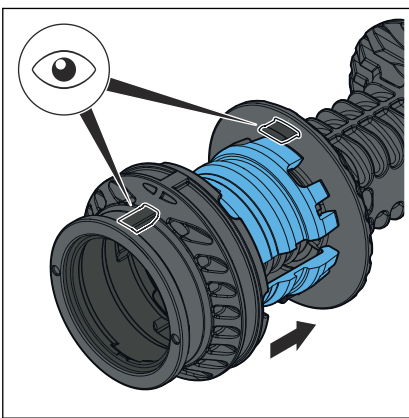

► Fit the slip coupling.

Position of the repair end

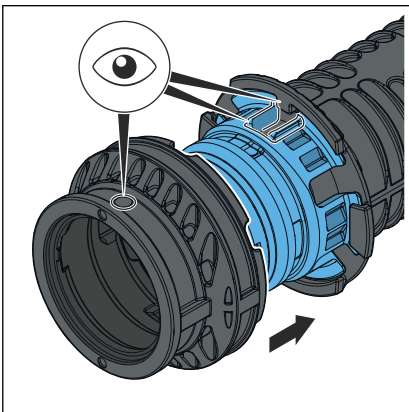

When mounting, observe the position of clamping ring and slip coupling.

3.3.2 Space requirements and intervals

Pressing between pipelines

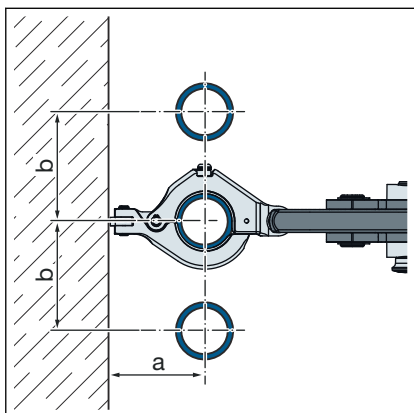

The minimum distance between pipelines is 50 mm for all dimensions.

Pressing between pipe and wall

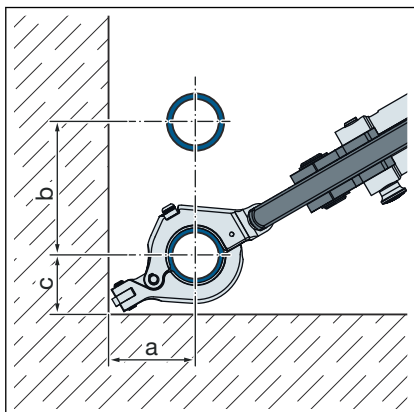

The minimum distance between pipe and wall is 50 mm for all dimensions.

Wall distance

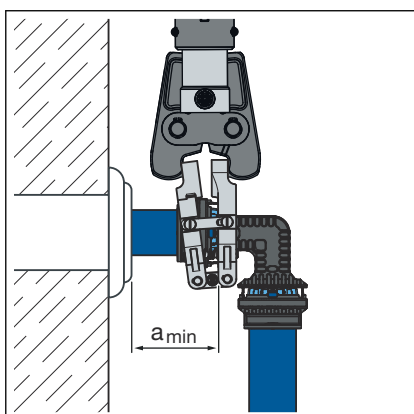

Minimum distance with d 32–63

d	a _{min} [mm]
32	90
40	96
50	100
63	105

Small wall distance

Use press ring drive model 9796.2 for smaller wall distance.

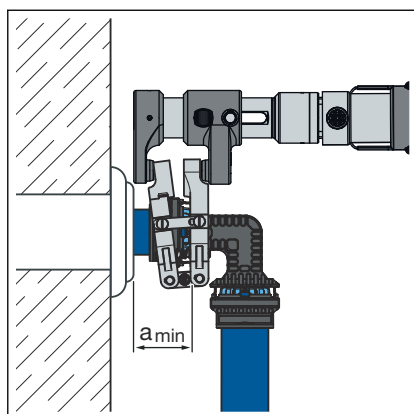

d	a _{min} [mm]
32	75 mm
40	80 mm
50	80 mm
63	85 mm

Interval between the pressings



NOTICE! Leaking press connections due to pipes being too short!

If two press connectors are to be mounted onto a pipe at a short distance apart, the pipe must not be too short. If the pipe is not inserted up to the prescribed insertion depth in the press connector during pressing, the connection may become leaky.

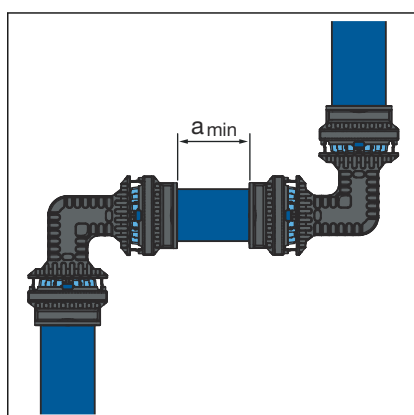

Minimum distance with press rings d32–63

d	a _{min} [mm]
32	20
40	20
50	20
63	20

Z dimensions

For the Z dimensions, refer to the respective product page in the online catalogue.

3.3.3 Required tools

The following tools are required for production of a press connection:

- Pipe cutter, pipe shear or saw
- Deburrer and coloured pen for marking
- Battery-powered press machine
- Hinged adapter jaw model 2296.2
 - Z2 with 32–63 mm diameter
- Press ring model 9796.1
- Press ring drive model 9796.2 (optional)



Viega recommends the use of Viega system tools when installing the press fittings.

The Viega system press tools have been developed and tailored specifically for the installation of Viega press connector systems.

3.4 Assembly

3.4.1 Cutting pipes to length

For information about tools, also see [Chapter 3.3.3 'Required tools'](#) on page 14.

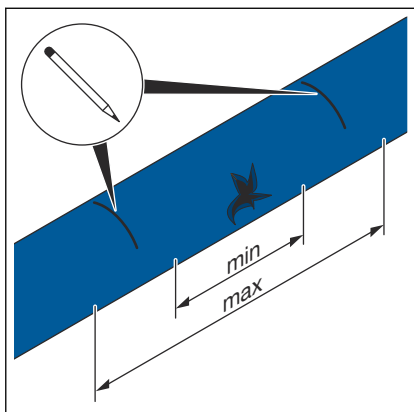

► Mark a piece of pipe length $X_{\min/\max}$ according to the following table.

d_a [mm]	X_{\min} [mm]	X_{\max} [mm]
32	52	105
40	59	115
50	72	115
63	81	120

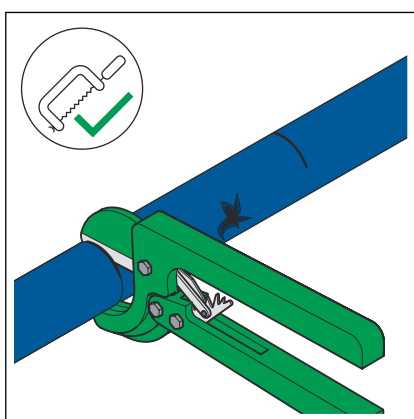
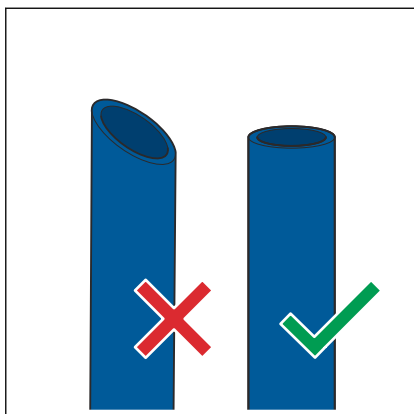

- Cut the pipe to length at a right angle as accurately as possible using pipe shears, a pipe cutter or a saw to ensure correct and even pipe insertion depth.

3.4.2 Deburring the pipes

- If a burr appears when the pipes are cut, then the pipe ends must be carefully deburred on the inside and outside.

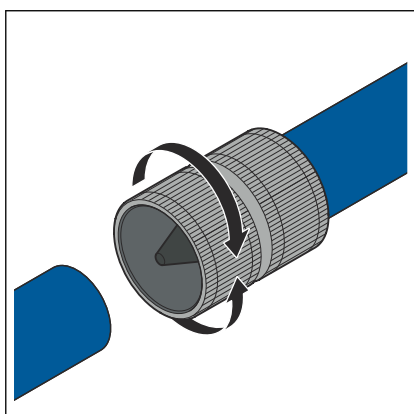

- Deburr the inside and outside of the pipe.

3.4.3 Pressing the connection

Requirements:

- The pipe end is not bent or damaged.
- The pipe is deburred.
- Check the internal and external pipe surfaces for contamination, and clean them as required. Remove any shavings.

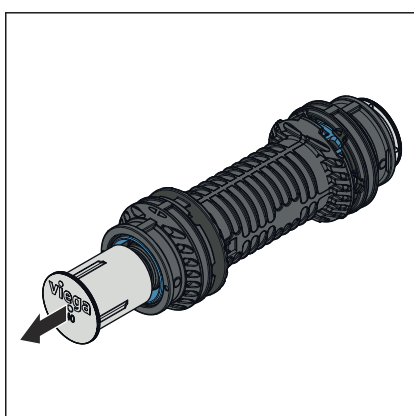
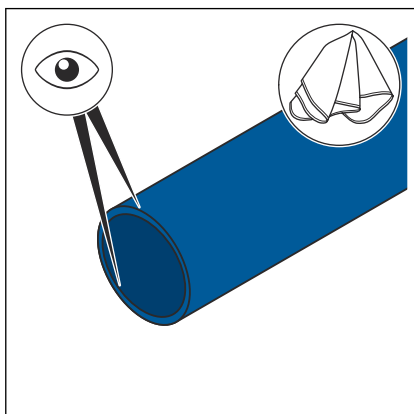

- Remove the protective cap from the repair end.

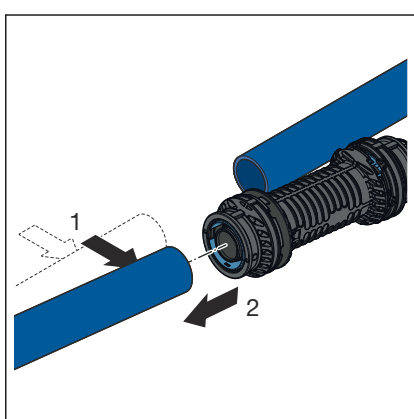

- Bend the pipe end sideways.
- Push on the repair coupling.

INFO! If the repair end is difficult to fit onto the pipe, a lubricant approved for use with potable water may be used.

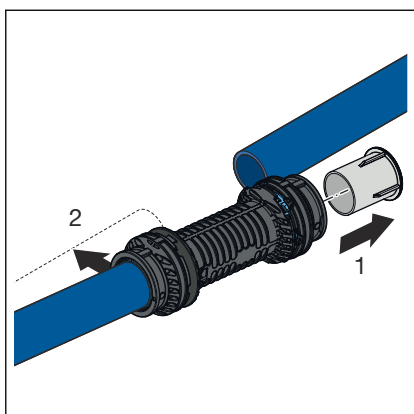

- Remove the protective cap from the standard press end.
- Return the pipe to its original position.

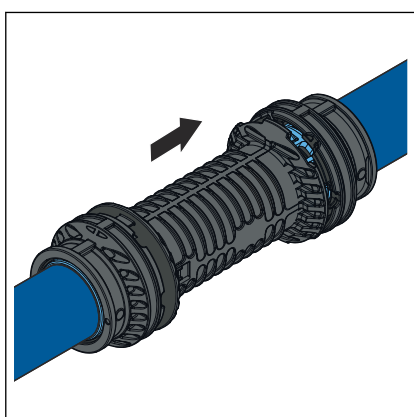

- Push the repair coupling back.

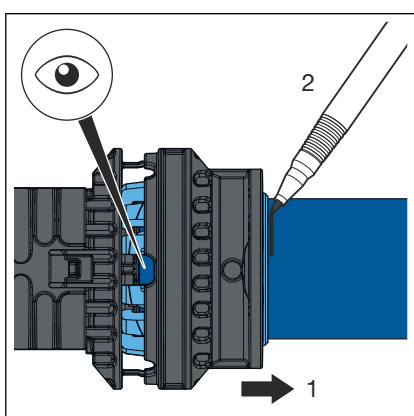

- Check the insertion depth in the inspection window of the standard press end and mark it.

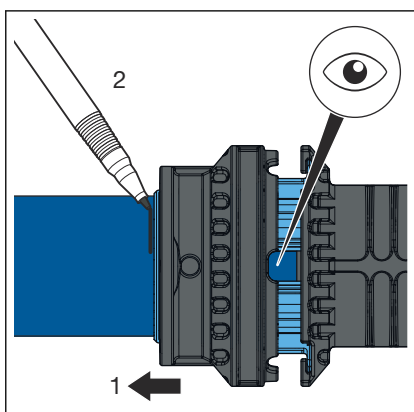

- Check the insertion depth in the inspection window of the repair end and mark it.

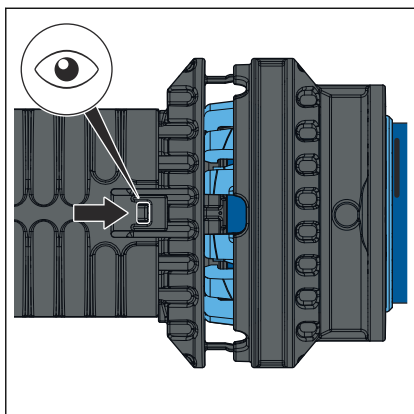

- Ensure that the sleeve is properly positioned.

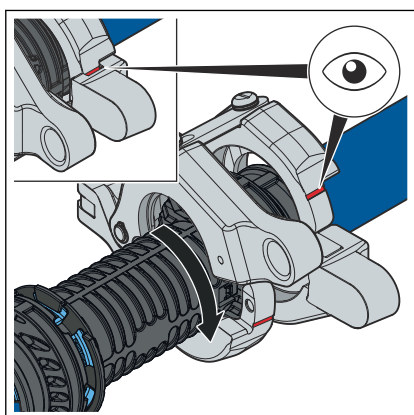

- Open the press ring and position it on the standard press end. Observe the press connector side and pipe side of the press ring. The press ring is properly closed when the red marking can no longer be seen.

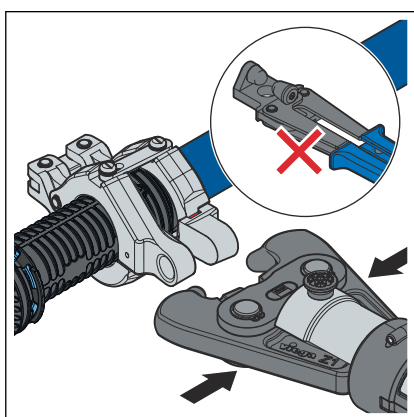

- Open the hinged adapter jaw, and latch it into the press ring holder.

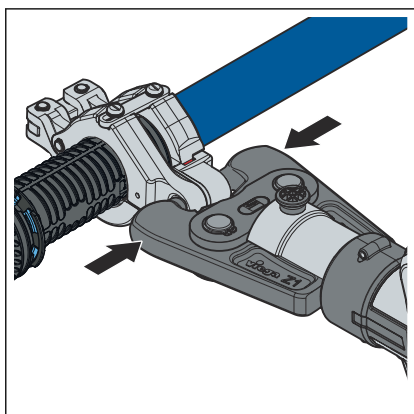

- Carry out the pressing.

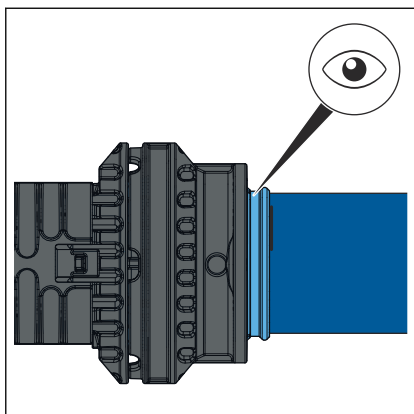

- The coloured clamping ring is easily recognised after successful pressing.
- The connection is marked as having been pressed.

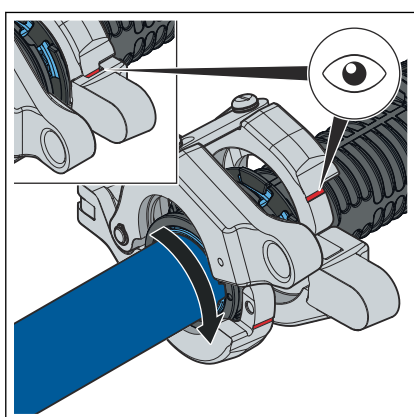

- Open press ring and place onto the repair end of the press connector.
- Observe the press connector side and pipe side of the press ring.
- The press ring is properly closed when the red marking can no longer be seen.

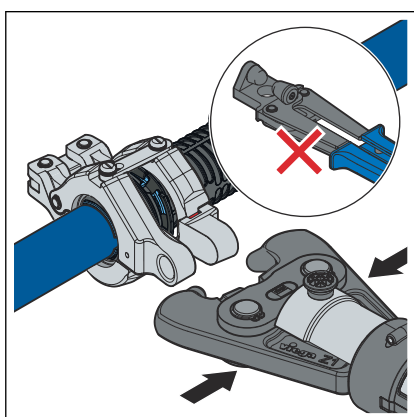

- Open the hinged adapter jaw, and latch it into the press ring holder.

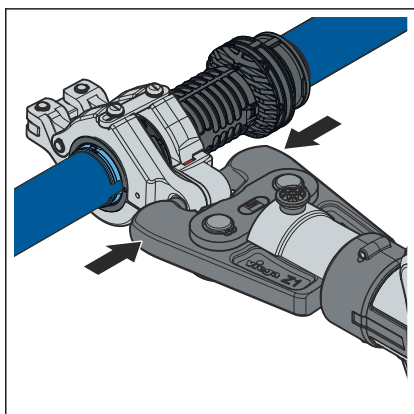

- Carry out the pressing.

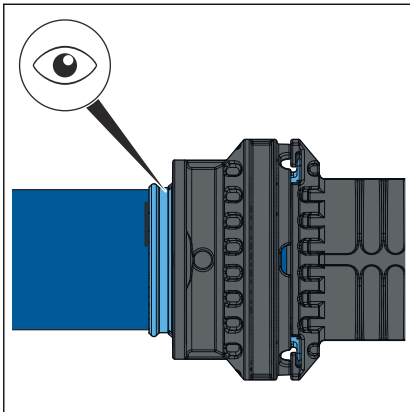

■ The coloured clamping ring is easily recognised after successful pressing.

□ The connection is marked as having been pressed.

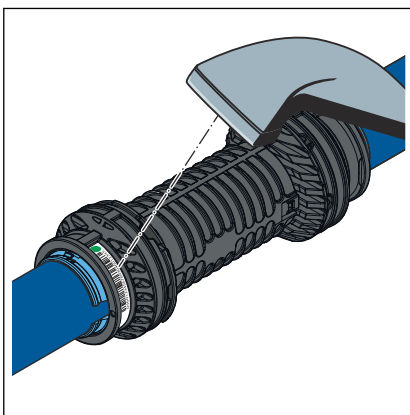

■ Scan in the traceability code.

3.4.4 Leakage test

Perform a leakage test according to the applicable regulations before commissioning the connection line, see [↗ 'Regulations from section: Leakage test' on page 6](#).

Carry out the test on a service connection that is finished but not yet covered. The result of the leakage test must be documented as proof of the safety of the pipeline.

3.5 Disposal

Separate the product and packaging materials (e. g. paper, metal, plastic or non-ferrous metals) and dispose of in accordance with valid national legal requirements.



Viega GmbH & Co. KG
service-technik@viega.de
viega.com

INT • 2024-03 • VPN230506

